



DIESEL GENERATING SETS  
INSTALLATION RECOMMENDATIONS  
and  
OPERATIONS MANUAL

**AKSA POWER DIESEL**

**MANUFACTURER COMPANY  
AKSA JENERATÖR SANAYİ A.Ş.**

Gülbahar Caddesi  
I. Sokak 34212 No: 2  
Güneşli / İSTANBUL  
T: + 90 212 478 66 66  
F: + 90 212 657 55 16  
e-mail: aksa@aksa.com.tr

**AUTHORIZED SERVICE  
AKSA SERVICE & SPARE PARTS**

Muratbey Beldesi,  
Güney Girişi Caddesi No:8  
34540 Çatalca / İSTANBUL  
T: + 90 212 887 11 11  
F: + 90 212 887 10 20  
e-mail: info@aksaservis.com.tr



## Dear Aksa Generating Set Users;

First of all, we would like to thank you for your choice of Aksa Generating Set.

It is solid, safe and reliable machine, built according to the latest technology.

This operating and maintenance manual is designed and developed to make you familiar with the generating system.

Please read the following instructions carefully before starting to use your machine.

This manual gives general information about mounting, operation and maintenance of the generating set. Tables and diagrams are also available outlining your generating set.

Never operate, maintain or repair your generating set without taking general safety precautions.

Aksa Jeneratör does not assume responsibility for possible errors.

Aksa Jeneratör reserves to make changes without prior notice.

|           |  |           |
|-----------|--|-----------|
| <b>1.</b> | <b>INTRODUCTION .....</b>                          | <b>3</b>  |
| <b>2.</b> | <b>GENERAL SAFETY PRECAUTIONS.....</b>             | <b>4</b>  |
| 2.1       | General.....                                       | 4         |
| 2.2.      | Installation Handling and Towing .....             | 4         |
| 2.3.      | Fire and Explosion.....                            | 4         |
| 2.4.      | Mechanical.....                                    | 5         |
| 2.5.      | Chemical.....                                      | 5         |
| 2.6.      | Noise.....   | 5         |
| 2.7.      | Electrical.....                                    | 6         |
| 2.8.      | First aid for Electric Shock.....                  | 6         |
| <b>3.</b> | <b>GENERAL DESCRIPTION .....</b>                   | <b>7</b>  |
| 3.1.      | Generating Set Description and Identification..... | 7         |
| 3.2.      | Generating Set Main Parts .....                    | 8         |
| 3.3.      | Diesel Engine .....                                | 8         |
| 3.4.      | Engine Electrical System .....                     | 8         |
| 3.5.      | Cooling System.....                                | 8         |
| 3.6.      | Synchronous Alternator.....                        | 8         |
| 3.7.      | Coupling.....                                      | 9         |
| 3.8.      | Fuel Tank and Base Frame.....                      | 9         |
| 3.9.      | Vibration Isolation .....                          | 9         |
| 3.10.     | Silencer and Exhaust System .....                  | 9         |
| 3.11.     | Control System.....                                | 9         |
| <b>4.</b> | <b>INSTALLATION HANDLING AND STORAGE .....</b>     | <b>9</b>  |
| 4.1.      | General.....                                       | 9         |
| 4.2.      | Canopies.....                                      | 9         |
| 4.3.      | Moving the Generating Set.....                     | 9         |
| 4.4.      | Location .....                                     | 10        |
| 4.5.      | Endosured Generating Set Location.....             | 10        |
| 4.6.      | Base and Foundation .....                          | 11        |
| 4.7.      | Room Design Guidance Notes.....                    | 12        |
| <b>5.</b> | <b>FUEL SYSTEM.....</b>                            | <b>16</b> |
| 5.1.      | General.....                                       | 16        |
| 5.2.      | Fuel Oil Recommendation.....                       | 16        |
| 5.3.      | Base Fuel Tank.....                                | 16        |
| 5.4.      | Bulk Storage Tanks .....                           | 17        |
| 5.5.      | Without Intermediate Fuel Tank.....                | 17        |
| 5.6.      | With Intermediate Fuel Tank .....                  | 17        |
| 5.7.      | Daily Service Fuel Tank.....                       | 17        |
| 5.8.      | Determining Pipe Sizes .....                       | 18        |
| 5.9.      | Fuel Return Lines.....                             | 18        |
| <b>6.</b> | <b>WATER TREATMENT .....</b>                       | <b>20</b> |
| 6.1.      | General.....                                       | 20        |
| 6.2.      | Engine Coolant .....                               | 20        |

|       |   |           |
|-------|---|-----------|
| 6.3.  | Engine Warming.....   | 20        |
| 7.    | <b>EXHAUST SYSTEM.....</b>  | <b>20</b> |
| 7.1.  | Sizing.....   | 20        |
| 7.2.  | Routing.....  | 21        |
| 8.    | <b>LUBRICATING OIL.....</b>   | <b>21</b> |
| 8.1.  | Oil Performance Properties.....   | 21        |
| 8.2.  | Lubrication Recommendation for engine.....  | 21        |
| 9.    | <b>ELECTRIC STARTING SYSTEM.....</b>  | <b>23</b> |
| 9.1.  | Battery Systems.....  | 23        |
| 9.2.  | Maintenance Batteries.....  | 23        |
| 9.3.  | Maintenance Free Batteries.....   | 23        |
| 9.4.  | Starting Aids.....  | 23        |
| 10.   | <b>ELECTRICAL CONNECTION.....</b>   | <b>23</b> |
| 10.1. | Cabling.....  | 23        |
| 10.2. | Loading.....  | 24        |
| 10.3. | Power Factor.....   | 24        |
| 10.4. | Grounding / Earthing Requirements.....  | 24        |
| 10.5. | Insulation Test.....  | 24        |
| 11.   | <b>ACUSTIC SILENCING.....</b>   | <b>25</b> |
| 11.1. | Exhaust Silencers.....  | 25        |
| 11.2. | Canopies.....   | 25        |
| 11.3. | Other Sound Attenuation.....  | 25        |
| 12.   | <b>TOWING (Mobile Generating Sets).....</b>   | <b>25</b> |
| 12.1. | Preparing to Tow.....   | 25        |
| 12.2. | Towing.....   | 25        |
| 12.3. | Parking.....  | 25        |
| 13.   | <b>STORAGE.....</b>   | <b>26</b> |
| 13.1. | Storage.....  | 26        |
| 13.2. | Alternator Storage.....   | 26        |
| 13.3. | Battery Storage.....  | 26        |
| 14.   | <b>GENERAL PRECAUTIONS and CONTROLS WHICH<br/>MUST BE DONE BEFORE STARTING UP THE<br/>GENERATING SET.....</b> | <b>26</b> |
| 15.   | <b>GENERAL PRECAUTIONS and CONTROLS WHICH<br/>MUST BE DONE AFTER STARTING UP THE<br/>GENERATING SET.....</b>  | <b>28</b> |
| 16.   | <b>CONTROL PANELS.....</b>  | <b>28</b> |
| 17.   | <b>THE PLACEMENT AND INSTALLATION OF<br/>TRANSFER SWITCH.....</b>   | <b>30</b> |
| 18.   | <b>ENGINETROUNLESHOOTING.....</b>   | <b>31</b> |
| 19.   | <b>GENERATING SET MAINTENANCE.....</b>  | <b>32</b> |
|       | <b>GENERAL PRECAUTIONS ABOUT WARRANTY.....</b>  | <b>34</b> |
|       | <b>ELECTRICAL WIRING DIAGRAMS</b>   |           |



## I. INTRODUCTION

This operating and maintenance manual is prepared to assist the operator in operation and maintenance of the generating set. Observing the advices and rules in this manual will ensure that the generating set operates in maximum performance and efficiency for a long time.

- Care should be taken to perform more frequent maintenance in dirty and dusty environments in order to keep the generating set in good working condition.

- Necessary adjustment and repairs should be made only by authorized and qualified persons.

- Each generating set has a model and a serial number indicated on a label on the base frame. This plate also indicates the manufacturing date, voltage, current, power in kVA, frequency, power factor and weight of the generating set. These datas are necessary in spare part orders, for warranty validity and for service calls.

|                          |         |                      |         |   |       |
|--------------------------|---------|----------------------|---------|---|-------|
| <b>AKSA</b>              |         |                      |         | Gülbaşar Cad. 1.Sok. Güneşli 34212 İstanbul / Türkiye<br>Tel: +90 212 478 66 66 Fax: +90 212 651 60 40<br>e-mail: aksa@aksa.com.tr http://www.aksa.com.tr |       |
| MODEL                    | _____   | PRODUCE DATE         | _____   | SERIAL NO   | _____ |
| PRIME KVA                | _____   | STANDBY KVA          |         |   |       |
| PRIME A                  | _____   | STANDBY A            |         |   |       |
| ALTERNATOR MODEL         | _____   | ALTERNATOR SERIAL NO |         |   |       |
| DIMENSIONS               | L _____ | W _____              | H _____ | FUEL TANK CAPACITY L  |       |
| VOLTS                    | _____   | GROUP WEIGHT kg.     |         | _____   |       |
| Hz                       | _____   | CoSp                 | _____   | _____   |       |
| PHASE                    | _____   | R.P.M                | _____   | _____   |       |
| " Assembled in Türkiye " |         |                      |         | ETK-025-10  |       |

The generating set is designed to be safe when used in correct manner. However responsibility for safety rests with the personnel who install, use and maintain the set. If the following safety precautions are followed, the possibility of accidents will be minimized. Before performing any procedure or operating technique, it is up to the user to ensure that it is safe. The generating set should only be operated by personnel who are authorized and trained.

Only people that have the right skills should be allowed to operate, adjust, perform maintenance or repair on Aksa Power Generation equipment. It is the responsibility of management to appoint operators with the appropriate training and skill for each category of job.

### Skill level 1 : Operator

An operator is trained in all aspects of operating the unit with the push- buttons, and trained to know the safety aspects.

### Skill level 2 : Mechanical technician

A mechanical technician is trained to operate the unit the same as the operator. In addition, the mechanical technician is also trained to perform maintenance and repair, as describe in the instruction manual, and is allowed to change settings of the control and safety system. A mechanical technician does not work on live electrical components.

### Skill level 3 : Electrical technician

An electrical technician and has the same qualifications as both the operator and the mechanical technician. In addition, the electrical technician may carry out electrical repairs within the various enclosures of the unit. This includes work on live electrical components.

### Skill level 4: Specialist from the manufacturer

This is skilled specialist sent by the manufacturer or its agent to perform complex repairs or modifications to the equipment. In general it is recommended that not more than two people operate the unit, more operators could lead to un safe operating conditions. Take necessary steps to keep unauthorized person away from the unit and eliminate all possible source of danger at the unit.

The manufacturer does not accept any liability for any damage arising from the use of non-original parts and for modifications, additions or conversions made without the manufacturer's approval in writing.

## 2. GENERAL SAFETY PRECAUTIONS

### 2.1. General

- ! The owner is responsible for maintaining the unit in a safe operating condition. Unit parts and accessories must be replaced if missing or unsuitable for safe operation.
- 2 Operate the unit only for the intended purpose and within its rated limits (pressure, temperature, speeds, etc.).
- 3 Gen-set and equipment shall be kept clean, i.e. as free as possible from oil, dust or other deposits.
- 4 To prevent an increase in working temperature, inspect and clean heat transfer surfaces (cooler fins, intercoolers, water jackets, etc.) regularly.
- 5 Take precautions against fire. Handle fuel, oil and anti-freeze with care because they are inflammable substances. Do not smoke or approach with naked flame when handling such substances. Keep a fire-extinguisher in the vicinity.

### WARNING

- ! Read and understand all safety precautions and warnings before operating or performing maintenance on the generating set.
- ! Failure to follow the instructions, procedures, and safety precautions in this manual may increase the possibility of accidents and injuries.
- ! Do not attempt to operate the generating set with a known unsafe condition.
- ! If the generating set is unsafe, put danger notices and disconnect the battery negative (-) lead so that it cannot be started until the condition is corrected.
- ! Disconnect the battery negative (-) lead prior to attempting any repairs or cleaning inside the enclosure.
- ! Install and operate this generating set only in full compliance with relevant National, Local or Federal Codes, Standards or other requirements.

### 2.2. Installation, Handling and Towing

Chapter 4 and 12 of this manual covers procedures for installation, handling and towing of generating sets. That chapter should be read before installing, moving and lifting the generating set or towing a mobile set. The following safety precautions should be noted:

### WARNING

- ! Make electrical connections in compliance with relevant Electrical Codes, Standards or other requirements. This includes requirements for grounding and ground/earth faults.
- ! For stationary generating sets with remote fuel storage systems, make sure such systems are installed in compliance with relevant Codes, Standards or other requirements.
- ! Engine exhaust emissions are hazardous to personnel. The engine exhaust for all indoor generating sets must be piped outdoors via leak-free piping in compliance with relevant Codes, Standards and other requirements. Ensure that hot exhaust silencers and piping are clear of combustible material and are guarded for personnel protection per safety requirements. Ensure that fumes from the exhaust outlet will not be a hazard.

- ! Never lift the generating set by attaching to the engine or alternator lifting lugs, instead use the lifting points on the base frame or canopy.



- ! Ensure that the lifting rigging and supporting structure is in good condition and has a capacity suitable for the load.
- ! Keep all personnel away from the generating set when it is suspended.

### 2.3. Fire and Explosion

Fuel and fumes associated with generating sets can be flammable and potentially explosive. Proper care in handling these materials can dramatically limit the risk of fire or explosion. However, safety dictates that fully charged BC and ABC fire extinguishers are kept on hand. Personnel must know how to operate them.

### WARNING

- ! Ensure that the generating set room is properly ventilated.
- ! Keep the room, the floor and the generating set clean. When spills of fuel, oil, battery electrolyte or coolant occur, they should be cleaned up immediately.
- ! Never store flammable liquids near the engine.
- ! Do not smoke or allow sparks, flames or other sources of ignition around fuel or batteries. Fuel vapors are explosive. Hydrogen gas generated by charging batteries is also explosive.

- ! Never store flammable liquids near the engine.
- ! Do not smoke or allow sparks, flames or other sources of ignition around fuel or batteries. Fuel vapors are explosive. Hydrogen gas generated by charging batteries is also explosive.



- ! Turn off or disconnect the power to the battery charger before making or breaking connections with the battery.
- ! To avoiding arcing keep grounded conductive objects (such as tools) a way from exposed live electrical parts (such as terminals). Sparks and arcing might ignite fuel or vapors.
- ! Avoid refilling the fuel tank while the engine is running.
- ! Do not attempt to operate the generating set with any known leaks in the fuel system.



#### 2.4. Mechanical

The generating set is designed with guards for protection from moving parts. Care must still be taken to protect personnel and equipment from other mechanical hazards when working around the generating set.

#### WARNING

- ! Do not attempt to operate the generating set with the safety guards removed. While the generating set is running do not attempt to reach under or around the guards to do maintenance or for any other reason.
- ! Keep hands, arms, long hair; loose clothing and jewelers away from pulleys, belts and other moving parts.



**Attention:** Some moving parts cannot be seen clearly when the set is running.

- ! If equipped keep access doors on enclosures closed and locked when not required to be open.



- ! Avoid contact with hot oil, hot coolant, hot exhaust gases, hot surfaces and sharp edges and corners.

- ! Wear protective clothing including gloves and hat when working around the generating set.
- ! Do not remove the radiator filler cap until the coolant has cooled. Then loosen the cap slowly to relieve any excess pressure before removing the cap completely.



#### 2.5. Chemical

Fuels, oils, coolants, lubricants and battery electrolyte used in this generating set are typical of the industry. However; they can be hazardous to personnel if not treated properly.

#### WARNING

- ! Do not swallow or allow skin contact with fuel, oil, coolant, lubricants or battery electrolyte. If swallowed, seek medical treatment immediately. Do not induce vomiting if fuel is swallowed. For skin contact, wash with soap and water.
- ! Do not wear clothing that has been contaminated by fuel or lube oil.
- ! Wear an acid resistant apron and face shield or goggles when servicing the battery. If electrolyte is spilled on skin or clothing, flush immediately with large quantities of water.



#### 2.6. Noise

Generating sets that are not equipped with sound attenuating enclosures can produce noise levels in excess of 105 dB(A). Prolonged exposure to noise levels above 85 dB(A) is hazardous to hearing.



#### WARNING

Ear protection must be worn when operating or working around an operating generating set.

## 2.7. Electrical

Safe and efficient operation of electrical equipment can be achieved only if the equipments is correctly installed, operated and maintained.

### WARNING

! The generating set must be connected to the load only by trained and qualified electricians who are authorized to do so, and in compliance with relevant Electrical Codes, Standards and other regulations.

! Ensure that the generating set, including a mobile set is effectively grounded/earthed in accordance with all relevant regulations prior operation.

! The generating set should be shutdown with the battery negative (-) terminal disconnected prior to attempting to connect or disconnect load connections.

! Do not attempt to connect or disconnect load connections while standing in water or on wet or soggy ground.

! Do not touch electrically energized parts of the generating set and/or interconnecting cables or conductors with any part of the body or with any non insulated conductive object.



! Replace the generating set terminal box cover as soon as connection or disconnection of the load cables is complete. Do not operate the generating set without the cover securely in place.

! Connect the generating set only to loads and/ or electrical systems that are compatible with its electrical characteristics and that are within its rated capacity.

! Keep all electrical equipment clean and dry. Replace any wiring where the insulation is cracked, cut, abraded or otherwise degraded. Replace terminals that are worn, discolored or corroded. Keep terminals clean and tight.

! Insulate all connections and disconnected wires.

! Use only Class BC or Class ABC extinguishers on electrical fires.

## 2.8. First Aid For Electric Shock

### WARNING

! Do not touch the victim's skin with bare hands until the source of electricity has been turned off.

! Switch off power if possible other wise pull the plug or the cable away from the victim.

! If this is not possible, stand on dry insulating material and pull the victim clear of the conductor; preferably using insulated material such as dry wood.

! If victim is breathing, turn the victim clear of the conductor; preferably using insulated material such as dry wood.

! If victim is breathing, turn the victim into the recovery position described below. If victim is unconscious, perform resuscitation as required;

### Open the airway

Tilt the victim's head back and lift the chin upwards. Remove objects from the mouth or throat (including false teeth, tobacco or chewing gum).



### Breathing

Check that the victim is breathing by looking, listening and feeling for the breath.



### Circulation

Check for pulse in the victim's neck.

### If no breathing but pulse is present



- Pinch the victim's nose firmly.
- Take a deep breath and seal your lips around the victim's lips.
- Blow slowly into the mouth watching for the chest to rise.
- Let the chest fall completely.



Give breaths at a rate of 10 per minute.

- If the victim must be left to get help, give 10 breaths first and then return quickly and continue.
- Check for pulse after every 10 breaths. When breathing restarts, place the victim into the recovery position described later in this section.

### If no breathing and no pulse

- Call or telephone for medical help.
  - Give two breaths and start chest compression as follows:
  - Place heel of hand 2 fingers breadth above ribcage/breastbone junction.
  - Place other hand on top and interlock fingers.
  - Keeping arms straight, press down 4-5 cm at a rate of 15 times per minute.
  - Repeat cycle (2 breaths and 15 compressions) until medical help takes over.
  - If condition improves, confirm pulse and continue with breaths.
- Check for pulse after every 10 breaths.
- When breathing restarts, place the victim into the recovery position described below.

### 3.6. Recovery position

- Turn the victim onto the side.
- Keep the head tilted with the jaw forward to maintain the open airway.
- Make sure the victim cannot roll forwards or backwards.
- Check for breathing and pulse regularly. If either stops, proceed as above.

### WARNING

! Do not give liquids until victim is conscious.

## 3. GENERAL DESCRIPTION

### 3.1. Generating Set Description and Identification

Diesel-electric generating sets are independent units for the production of electric power; basically, they comprise a constant voltage synchronous generator driven by an internal - combustion, diesel -cycle engine.

The sets are used for two main purposes:

#### a- Continuous duty sets,

used to produce electric power for countless requirements (motive power, lighting, heating, etc) in areas where other sources of power are unavailable.

#### b- Emergency duty sets,

Used during public network failures, when such failures are liable to cause serious trouble to persons or material or financial damage (i.e. in hospitals, industrial plants with non-stop operating cycles, etc) or to meet peak energy demands.

According to their application, the sets are further divided into:

- set for use on land
- set for use at sea

The sets for use on land can be either :

- stationary sets (fixed installation), or
- mobile sets (mobile installation)

These two types of sets are available in a vast range of versions, for every operating requirement, the main ones being:

01. hand control generating sets
02. stand-by generating sets

The standard stationary generating set comprises:

- diesel engine
- synchronous generator
- coupling
- metal sub-base with vibration isolators
- starter batteries
- fuel tank within the bed-plate
- instrument panel
- exhaust gas silencer.

Aksa Generating Set has been designed as a complete package to provide superior performance and reliability. Figure 3.1. identifies the major components. This figure is of a typical generating set. However, every set will be slightly different due to the size and configuration of the major components. This section briefly describes the parts of the generating set. Further information is provided in later sections of this manual.

Each generating set is provided with a Rating Label (Item 1) generally fixed to the base frame. This label contains the

information needed to identify the generating set and its operating characteristics. This information includes the model number; serial number; output characteristics such as voltage and frequency, output rating in kVA and kW, product date and weight.

The model and serial numbers uniquely identify the generating set and are needed when ordering spare parts or obtaining service or warranty work for the set.

AC series generating sets are an Alternating Current generator; built for continuous running at sites where no electricity is available (some models are excepted) or as stand-by in case of interruption of the mains.

The generator operates at 230/220V in line-to-neutral mode and 400/440V in line-to-line mode. The AC series generating set is driven by a water-cooled diesel engine.

### 3.2. Generating Set Main Parts

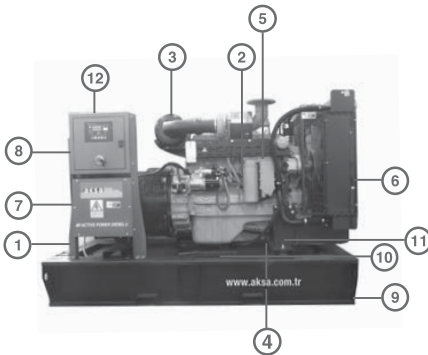

Figure 3.1. Typical generating set configuration

#### No Description

- |     |                                   |
|-----|-----------------------------------|
| 1.  | Aksa generating set rating label  |
| 2.  | Diesel engine                     |
| 3.  | Air filter                        |
| 4.  | Battery                           |
| 5.  | Battery charging alternator       |
| 6.  | Radiator                          |
| 7.  | Alternator                        |
| 8.  | Terminal box                      |
| 9.  | Base frame                        |
| 10. | Fuel tank (inside the base frame) |
| 11. | Vibration isolators               |
| 12. | Control Panel                     |

### 3.3. Diesel Engine

The diesel engine powering the generating set (Item 2) has been chosen for its reliability and the fact that it has been specifically designed for powering generating sets. The engine is of the heavy duty industrial type with 4 stroke compression ignition and is fitted with all accessories to provide a reliable power supply. These accessories include, among others, a cartridge type dry air filter (item 3) and a mechanical or an electronic engine speed governor. The engine cylinder block is cast in one piece cast iron, vertical cylinders inline overhead valves and camshaft in block or V- type, according to the type.

The cylinder heat is made of special cast iron. The thermally loaded flame plate is efficiently water cooled. The crankshaft is forged in one piece in a high tensile steel.

Lubrication: forced lubrication via gear pump, special paper cartridge -type filters, lubricant cooling via heat exchanger on most versions.

### 3.4. Engine Electrical System

The engine electrical system is 12 volt or 24 volts DC, negative ground/earth. This system includes an electric engine starter; a battery (item 4) and a battery charging alternator (item 5). For 12 volts electrical system one battery is given. For 24 volt system two lead-acid batteries are given. Other types of batteries may be fitted if they were specified.

### 3.5. Cooling System

The engine cooling system is water cooled. The water cooled system is comprised of a radiator (item 6) a pusher fan and thermostat. The alternator has its own internal fan to cool the alternator components.

### 3.6. Synchronous Alternator

Horizontal axle alternator (synchronous three phase), on rolling bearings, self-ventilated within the room with low-loss silicon-sheet stator bundle, electrolytic copper winding with class H insulation.

The output electrical power is normally produced by a screen protected and drip-proof, self-exciting, self

regulating, brushless alternator. (Item 7) Fine tuned to the output of this generating set. Mounted on top of the alternator is a sheet steel terminal box (item 8)

### 3.7. Coupling

Engine and alternator are firmly joined by a coupling cone that guarantees the proper assembly coaxiality. Mono-support machines are also used a special flexible disk is used in place of a flexible coupling.

### 3.8. Fuel tank and Base frame

The engine and alternator are coupled together and mounted on a heavy duty steel base-frame (Item 9). This base frame includes a fuel tank (Item 10) with capacity of approximately 8 hours operation under variable loads. The tank is complete with filling cap and fuel level gauge and is connected by flexible joints to the intake piping and to the overflow piping containing fuel from the injector drain. High power gen-set's fuel tank is separate from gen-set.

### 3.9. Vibration Isolation

The generating set is fitted with vibration isolators (Item 11) which are designed to reduce engine vibration being transmitted to the foundation on which the generating set is mounted. These isolators are fitted between the engine /alternator feet and the base frame.

### 3.10. Silencer and Exhaust system

Exhaust gases from the turbocharger are discharged toward atmosphere through a silencer. These should be vented as high as possible, and must be prevented from re-entering the engine via the charge air intake, or polluting the radiator fins.

It is important to note that the turbocharger nozzles must be always free of loads. Stainless steel exhaust compensator is delivered with generator set. Exhaust lines of different engines shall not be mixed in a common stack, but routed separately in individual ducts, enclosed in a chimney.

Suitable material is carbon steel sheet, and recommended calculation temperature is 525°C. Rain and condensate permanent draining shall be provided to prevent water

entering the silencer and the engine.

An exhaust silencer is provided loose for installation with the generating set. The silencer and exhaust system reduce the noise emission from the engine and can direct exhaust system reduce the noise emission from engine and can direct exhaust gases to safe outlets.

The exhaust silencer is made of a carbon steel receiver containing sound attenuator and wave de-phasing system made of perforated steel sheet and heavy rock wool. It is asbestos-free. The exhaust silencer is delivered in two configurations with an industrial attenuation and residential attenuation.

#### 3.11. Control System

One of several types of control systems and panels (item 12) may be fitted to control the operation and output of the set and to protect the set from possible malfunctions. Section 15 of this manual provides detailed information on these systems and will aid in identification of the control system fitted on the generating set.

## 4. INSTALLATION AND HANDLING

### 4.1. General

Once the size of the generating set and any associated control systems or switchgear have been established, plans for installation can be prepared. This section discusses factors important in effective and safe installation of the generating set.

### 4.2. Canopies

Installation and handling is simplified when the generating set has been equipped with a canopy. The canopy also gives protection from the elements and protection from unauthorized access.

### 4.3. Moving the Generating Set

The generating set base frame is specifically designed for ease of moving the set. Improper handling can seriously damage components. Using a forklift, the generating set can be lifted or carefully pushed/pulled by the base frame directly with fork. Always use wood between forks and the base frame to spread the load and prevent damage.

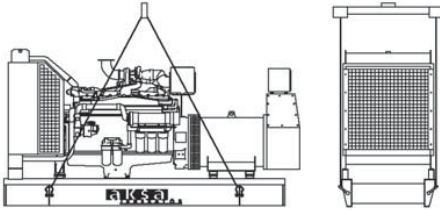

**Figure 4.1.** Lifting generating set by using a winch

### Warning

- ! Never lift the generating set by attaching to the engine or alternator lifting lugs.
- ! Ensure the lifting rigging and supporting structure is in good condition and is suitably rated.
- ! Keep all personnel away from the generating set when it is suspended.
- ! If the generating set is going to be lifted, it should be lifted by the lifting points fitted on canopied sets and most open sets.

### 4.4. Location

In order to start to consider the possible layouts for a site, the following criteria must first be determined:

- The total area available and any restrictions within that area (i.e. buried or overhead services)
- The access to the site, initially for delivery and installation purposes, but afterwards for the deliveries of fuel and servicing vehicles, etc.
- Ground condition, is it level or sloping?
- Any noise constraints. (i.e. the location of offices or residential property).
- A forced ventilation system is required for the equipment, which draws sufficient cooling and aspiration air into the room at the back of the alternator and discharges the air from in front of the engine. Dependent upon the layout of the building, it may be necessary to install additional ductwork to achieve the airflow required.
- The access into the building, initially for the delivery and installation of the equipment, and afterwards for servicing and maintenance of the equipment.
- Protection from the elements such as rain, snow, sleet, wind driven precipitation, flood water, direct

sunlight, freezing temperatures or excessive heat.

- Protection from exposure to airborne contaminants such as abrasive or conductive dust, lint, smoke, oil mist, vapors, engine exhaust fumes or other contaminants.
- Protection from impact from falling objects such as trees or poles, or from motor vehicles or lift trucks.
- Clearance around the generating set for cooling and access for service: at least 1 meter around the set and at least 2 meters headroom above the set.
- Access to move the entire generating set into the room. Air inlet and outlet vents can often be made removable to provide an access point. Limited access to unauthorized personnel.
- If it is necessary to locate the generating set outside of the building, the generating set should be enclosed in a canopy. A canopy is also useful for temporary installations inside or outside the building.

### 4.5. Enclosed Generating Set Location

#### 4.5.1. Positioning and preparing for installation

Select a position for the enclosed generator that the following conditions are met:

- Do not install generator where exhaust gas could accumulate and enter inside or be drawn into a potentially occupied building. Ensure exhaust gas is kept a way from any windows, doors, ventilation intakes or other openings that can allow exhaust gas to collect in a confined area.
- The positioning of the enclosed generator should be such that generator exhaust and cooling air flows do not create a nuisance or potential source of danger to personnel or buildings etc.
- Prevailing wins and air currents should be taken into consideration when positioning generator.
- Place the unit in a prepared location that is flat and has provisions for water drainage.
- Install the unit in a location where sump pump discharge, rain gutter down spouts, roof run-off, landscape irrigation or water sprinklers will not flood the unit or spray the enclosure and enter any air inlet our outlet openings.
- Protection from the elements such as rain, snow, sleet, wind driven precipitation, flood water, direct sunlight, freezing temperatures or excessive heat.



- Protection from exposure to airborne contaminants such as abrasive or conductive dust, lint, smoke, oil mist, vapors, engine exhaust fumes or other contaminants.
- Protection from impact from falling objects such as trees or poles or from motor vehicles or lift trucks.
- Install the unit where the location of any services such as phone, electrical, fuel, air conditioning, irrigation, including covered, concealed and underground services will not be affected or obstructed.
- Install the unit where air inlet and outlet openings will not become obstructed by leaves, grass, snow, etc. If prevailing winds will cause blowing or drifting, you may need to construct a windbreak to protect the unit.
- The ground must be dry, level and firm enough to support the weight of the enclosure without any sinking with time. A prepared concrete platform with a smooth surface is necessary to accommodate the generating set. Allowance for cable runs and if necessary, fuel pipes from a bulk tank must be made into the concrete slab. Check which side of the set fuel lines and cables originate from.
- There must be adequate access for installation and commissioning of the generator. Also allowance must be made for maintenance.
- Inspection of exhaust system for leaks and damage and that no materials or debris can come into contact with the hot exhaust system.
- Inspection of exhaust pipe exit for obstruction.
- Do not install the generator closer 1,5m from any combustibles or structures with combustible walls
- The enclosure protection class is IP 23 specifications.
- All non-current carrying metalwork associated with the equipment must be bonded to a suitable earth connection.
- Select a position for the enclosed generator which is as close as possible to the load.

**4.6. Base and Foundation**

Note: Special foundation are unnecessary. A level and sufficiently strong concrete floor is adequate. The responsibility for the foundation (including seismic considerations) should be placed with a civil or structural engineer specializing in this type of work.

Major functions of a foundation are to:

Support the total weight of the generating set.  
Isolate generator set vibration from surrounding structures.

To support the structural design, the civil engineer will need the following details:

- the plant's operating temperatures
- the overall dimensions of the proposed foundation mass,
- the mounting and fixing arrangements of the generator bed-frame.

**Concrete Foundations**

The foundation will require at least seven days between pouring the concrete and mounting the generating set to cure. It also essential that the foundation should be level, preferably within ± 0,5° of any horizontal plane and should rest on undisturbed soil.

The following formula may be used to calculate the minimum foundation depth:

$$t = \frac{k}{d \times w \times l}$$

- t = thickness of foundation in m
- k = net weight of set in kg
- d = density of concrete (take 2403 kg/m<sup>3</sup>)
- w = width of foundation in (m)

The foundation strength may still vary depending on the safe bearing capacity of supporting materials and the soil bearing load of the installation site, therefore reinforced gauge steel wire mesh or reinforcing bars or equivalent may be required to be used.

**Vibration Isolation**

Each generating set is build as a single module with the engine and alternator coupled together through a coupling chamber with resilient mounting to form one unit of immense strength and rigidity. This provides both accuracy of alignment between the engine and alternator and damping of engine vibration. Thus heavy concrete foundations normally used to absorb engine vibration are not necessary and all the generator requires is a

level concrete floor that will take the distributed weight of the unit.

#### **Foundation**

A reinforced concrete pad provides a rigid support to prevent deflection and vibration. Typically the foundation should be 150 mm to 200 mm ( 6 to 8 inches) deep and at least as wide and long as the generating set. The ground or floor below the foundation should be properly prepared and should be structurally suited to carry the weight of the foundation pad and the generating set. (If the generating set is to be installed above the ground floor the building structure must be able to support the weight of the generating set, fuel storage and accessories). If the floor may be wet from time to time such as in a boiler room, the pad should be raised above the floor. This will provide a dry footing for the generating set and for those who connect, service or operate it. It will also minimize corrosive action on the base-frame.

#### **Levelling**

A poor foundation may result in unnecessary vibration of the plant.

#### **Connections**

All piping and electrical connections should be flexible to prevent damage by movement of the plant. Fuel and water lines, exhaust pipes and conduit can transmit vibrations at long distances.

### **4.7. Room Design Guidance Notes**

#### **4.7.1. Room size allowance**

The dimensions as indicated A & B allow for good maintenance /escape access around the generator. Ideally you should allow a minimum distance of 1 meter from any wall, tank or panel within the room.

#### **4.7.2. Inlet and outlet attenuators with weather louvers**

The inlet and outlet attenuators should be installed within a wooden frame and are based on 100 mm. Airways with 200 mm. Acoustic modules. The attenuators should be fitted with weather louvers with a minimum 50 % free area, good airflow profile and afford low restriction airflow access.

The weather louvers should have bird/vermin mesh screens fitted on the inside, but these screens must not impede the free flow of cooling and aspiration air. The outlet attenuator should be connected to the radiator ducting flange with a heat and oil resistant flexible connection

#### **4.7.3. Combustion Air Inlet**

Air for engine combustion must be clean and as cool as possible. Normally this air can be drawn from the area surrounding the generating set via the engine mounted air filter. However, in some cases due to dust, dirt or heat the air around the set is unsuitable. In these cases an inlet duct should be fitted. This duct should run from the source of clean air (outside the building, another room, etc) to the engine mounted air filter. Do not remove the air filter and mount it at a remote location as this can increase the possibility of dirt leaking through the ductwork and into the engine inlet.

#### **4.7.4. Exhaust systems**

The exhaust systems shown on the layout drawings are supported from the ceiling. Should the building construction be such that the roof supports were unable to support the exhaust system, a floor standing steel exhaust stand will be needed. Exhaust pipes should terminate at least 2,3 m above floor level to make it reasonable safe for anyone passing or accidentally touching.

It is recommended that stainless steel bellows be fitted to the engine exhaust manifold followed by rigid pipe work to the silencer. It is good installation practice for the exhaust system within the generator room to be insulated with a minimum of 50 mm. of high density, high temperature mineral insulation covered by an aluminium over clad. This reduced the possibility of operator burn injury and reduces the heat being radiated to the operating generator room.

#### 4.7.5. Cooling and Ventilation

The engine, alternator and exhaust piping radiate heat which can result in a temperature high enough to adversely affect the performance of the generating set. It is therefore important that adequate ventilation is provided to keep the engine and alternator cool. Proper air flow, as shown in Figure 3.4. requires that the air comes in at the alternator end of the set, passes over the engine, through the radiator and out of the room via a flexible exhaust duct. Without the ducting of the hot air outside the room, the fan will tend to draw that hot air around and back through the radiator, reducing the cooling effectiveness.

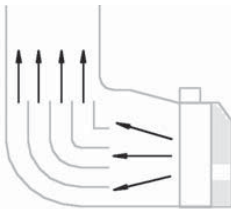

**Figure 4.2.**  
Directing the air thrown from the radiator with deviating wings

Sharp corners on the radiator hot air outlet channel or its chimney must be avoided. Some rearrangements to turn thrown air should be done (Figure 4.2. and 4.3.)

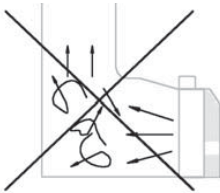

**Figure 4.3.** Weak ventilation

The air inlet and outlet openings should be large enough to ensure free flow of air into and out of the room. As rough guide the openings should each be at least 1,5 times the area of the radiator core.

Both the inlet and outlet openings should have louvers for weather protection. These may be fixed but preferably should be movable in cold climates so that while the generating set is not operating the louvers can be closed. This will allow the room to be kept warm which will

assist starting and load acceptance. For automatic starting generating sets. If the louvers are movable they must be automatically operated. They should be programmed to open immediately upon starting the engine

#### 4.7.6. Cable systems

The layout drawings assumes that the change-over, switch-gear is external to the generator room and located in the power distribution room. Specific project requirements can affect this layout.

The power output cables from the generator output breaker to the distribution panel must be of a flexible construction.

The flexible power cables as installed should be laid up in trefoil, placed on support trays/ladder rack in the trench with the recommended inter-spacing and segregated from the system control cables. The cables should be correctly supported and rated for the installation/ambient conditions.

The flexible single core power cables when entering any panel must pass through a non-ferrous gland plate.

#### 4.7.7. Change - over panels

Should the change-over panel with in the generator room.

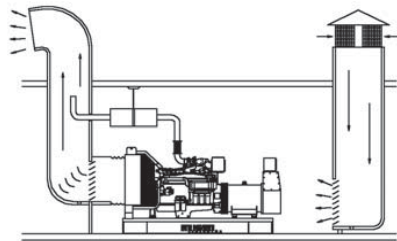

**Figure 4.4.** Air ventilation

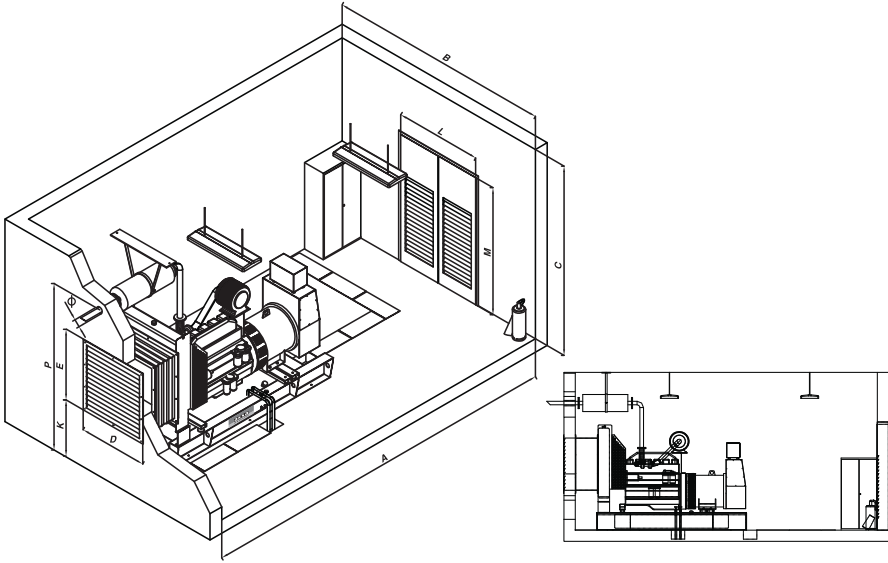

Figure 4.5. Generating Set Room

**AIR EXHAUST**

Hot air from the generating set is discharged from the room through a hot air duct (optional) fitted in an opening in the wall the same size as the duct. The hot air discharge opening is protected from any obstruction, penetration or infiltration of foreign elements by a metal louvre. Use a neoprene foam to seal the hot air discharge duct in the wall. The exhaust pipe is fitted in the hot air discharge duct. Hot air from the radiator passes through the canopy roof.

**AIR INLET**

Air inlet louvre on door or Wall.  
**AIR INLET SURFACE**  
 minimum x 2 the air exhaust area.

**ELECTRIC CABLES**

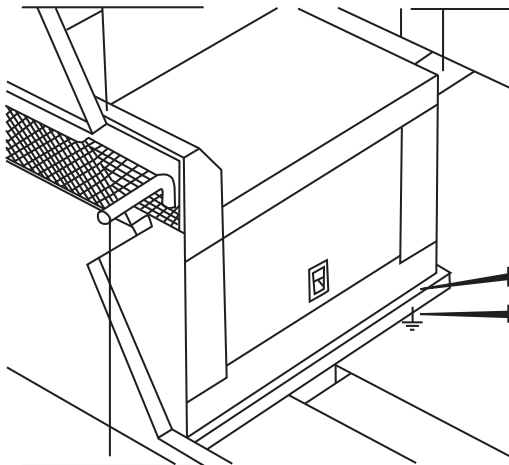

**GENERATING SET BOLTED TO THE SLAB**

**EARTH TERMINAL**

**EXHAUST GASES DISCHARGE OUTSIDE THE ROOM**

When the original piping must be extended, should be mounted on an efficient suspension bracket fitted and muffler bellows between piping and muffler. It must never rest on the engine or muffler.

Figure 4.6. Soundproof type Generating set room

| Generating Sets |                     | Generating Set Dimensions (m) |       |        | Room Dimension (m) |       |        | Radiator Hot Air Outlet Openings Louvers (m) |      |      | Air Inlet Openings Total Area | Room's Door Dimension (m) |     | Exhaust           |       |
|-----------------|---------------------|-------------------------------|-------|--------|--------------------|-------|--------|--|------|------|-------------------------------|---------------------------|-----|-------------------|-------|
| Model           | Standby Power (kVA) | Length                        | Widht | Height | A                  | B     | C      | D  | E    | K    | [m <sup>2</sup> ]             | L                         | M   | Ø Diameter (inch) | P (m) |
|                 |                     |                               |       |        | Length             | Widht | Height |  |      |      |                               |                           |     |                   |       |
| APD 20 A        | 20                  | 1,5                           | 0,9   | 1,1    | 3,0                | 3,0   | 2,5    | 0,7  | 0,75 | 0,4  | 0,7                           | 1,5                       | 2,0 | 3,0               | 1,9   |
| APD 25 A        | 25                  | 1,5                           | 0,9   | 1,1    | 3,0                | 3,0   | 2,5    | 0,7  | 0,75 | 0,4  | 0,7                           | 1,5                       | 2,0 | 3,0               | 1,9   |
| APD 30 C        | 30                  | 1,86                          | 0,9   | 1,4    | 3,0                | 3,0   | 2,5    | 0,8  | 0,8  | 0,35 | 0,8                           | 1,5                       | 2,0 | 3,0               | 2,0   |
| APD 33 A        | 33                  | 1,5                           | 0,9   | 1,1    | 3,0                | 3,0   | 2,5    | 0,75   | 0,8  | 0,4  | 0,75                          | 1,5                       | 2,0 | 3,0               | 1,9   |
| APD 40 A        | 40                  | 1,73                          | 0,9   | 1,14   | 3,0                | 3,0   | 2,5    | 0,8  | 0,8  | 0,35 | 0,8                           | 1,5                       | 2,0 | 3,0               | 1,9   |
| APD 43 C        | 43                  | 1,86                          | 0,9   | 1,4    | 3,0                | 3,0   | 2,5    | 0,8  | 0,8  | 0,35 | 0,8                           | 1,5                       | 2,0 | 3,0               | 2,0   |
| APD 50 A        | 50                  | 1,86                          | 0,9   | 1,3    | 3,0                | 3,0   | 2,5    | 0,8  | 0,8  | 0,35 | 0,8                           | 1,5                       | 2,0 | 3,0               | 2,0   |
| APD 70 A        | 70                  | 1,86                          | 0,9   | 1,3    | 3,0                | 3,0   | 2,5    | 0,8  | 0,8  | 0,35 | 0,8                           | 1,5                       | 2,0 | 3,0               | 2,0   |
| APD 90 A        | 93                  | 2,15                          | 1,0   | 1,5    | 4,0                | 3,0   | 2,5    | 0,8  | 0,8  | 0,4  | 1,0                           | 1,5                       | 2,2 | 3,0               | 2,0   |
| APD 110 C       | 110                 | 2,15                          | 1,0   | 1,5    | 4,0                | 3,0   | 2,5    | 0,8  | 0,9  | 0,45 | 1,0                           | 1,5                       | 2,2 | 3,0               | 2,0   |
| APD 125 A       | 125                 | 2,3                           | 1,1   | 1,64   | 4,0                | 3,0   | 2,7    | 1,1  | 1,0  | 0,4  | 1,3                           | 1,5                       | 2,2 | 4,0               | 2,2   |
| APD 145 C       | 145                 | 2,3                           | 1,0   | 1,5    | 4,0                | 3,0   | 2,5    | 0,8  | 0,9  | 0,45 | 1,0                           | 3                         | 2,2 | 3,0               | 2,0   |
| APD 150 A       | 150                 | 2,3                           | 1,1   | 1,65   | 4,0                | 3,0   | 2,7    | 1,1  | 1,0  | 0,4  | 1,3                           | 1,5                       | 2,2 | 4,0               | 2,2   |
| APD 200 C       | 200                 | 2,4                           | 1,1   | 1,7    | 4,0                | 3,0   | 2,7    | 1,1  | 1,0  | 0,55 | 1,3                           | 1,5                       | 2,2 | 4,0               | 2,2   |
| APD 250 A       | 250                 | 3,0                           | 1,22  | 2,05   | 5,0                | 3,3   | 3,0    | 1,1  | 1,2  | 0,45 | 1,5                           | 1,5                       | 2,2 | 6,0               | 2,3   |
| APD 275 C       | 275                 | 2,9                           | 1,15  | 1,85   | 5,0                | 3,3   | 3,0    | 1,2  | 1,2  | 0,55 | 1,5                           | 1,5                       | 2,4 | 6,0               | 2,4   |
| APD 330 A       | 330                 | 3,2                           | 1,15  | 1,9    | 5,0                | 3,3   | 3,0    | 1,3  | 1,3  | 0,55 | 1,7                           | 1,5                       | 2,5 | 6,0               | 2,5   |
| APD 350 C       | 350                 | 3,25                          | 1,15  | 1,9    | 5,0                | 3,3   | 3,0    | 1,3  | 1,3  | 0,55 | 1,7                           | 1,5                       | 2,5 | 6,0               | 2,5   |
| APD 385 C       | 385                 | 3,25                          | 1,15  | 1,9    | 5,0                | 3,3   | 3,0    | 1,3  | 1,3  | 0,55 | 1,7                           | 1,5                       | 2,5 | 6,0               | 2,5   |
| APD 1000 C      | 1000                | 4,5                           | 1,77  | 2,35   | 7,0                | 4,0   | 4,5    | 2,0  | 2,0  | 0,3  | 5,0                           | 2,5                       | 3,0 | 2x6               | 3,0   |
| AJ 1375         | 1375                | 5,75                          | 2,1   | 2,7    | 9,0                | 5,0   | 4,5    | 2,4  | 2,5  | 0,4  | 7,0                           | 3,0                       | 3,5 | 1x12              | 3,5   |
| APD 1425 M      | 1425                | 4,4                           | 2,04  | 2,16   | 7,5                | 4,5   | 4,5    | 2,5  | 2,5  | 0,35 | 7,0                           | 3,0                       | 3,0 | 1x12              | 3,5   |
| APD 1540 M      | 1540                | 4,4                           | 2,04  | 2,16   | 7,5                | 4,5   | 4,5    | 2,5  | 2,5  | 0,35 | 7,0                           | 3,0                       | 3,0 | 1x12              | 3,5   |
| AJ 1600         | 1600                | 5,55                          | 2,15  | 2,6    | 8,0                | 5,0   | 4,5    | 2,5  | 2,5  | 0,4  | 7,0                           | 3,0                       | 3,5 | 1x12              | 3,5   |
| APD 1650 M      | 1650                | 4,95                          | 2,2   | 3,08   | 8,0                | 5,0   | 5,0    | 2,5  | 2,7  | 0,35 | 8,0                           | 3,0                       | 3,5 | 1x12              | 4,0   |
| APD 1915 M      | 1915                | 5,16                          | 2,25  | 2,55   | 8,0                | 5,0   | 4,5    | 2,7  | 2,5  | 0,35 | 7,0                           | 3,0                       | 3,5 | 1x16              | 3,5   |
| APD 2100 M      | 2100                | 5,23                          | 2,52  | 2,97   | 9,0                | 5,0   | 5,0    | 3,0  | 2,7  | 0,3  | 9,0                           | 3,0                       | 3,5 | 1x16              | 4,0   |
| APD 2225 M      | 2225                | 5,7                           | 2,4   | 3,22   | 9,0                | 5,0   | 5,0    | 2,7  | 3,0  | 0,3  | 9,5                           | 3,0                       | 3,5 | 1x16              | 4,0   |

**Table 4.1.** Aksa open type 50 Hz diesel gensets dimensions, room sizes, air inlet and outlet openings dimensions and exhaust pipe dimensions (look figure 4.5. genset room) Without acoustic treatment, single sets.

## 5. FUEL SYSTEM

### 5.1. General

Dependent upon the specific site layout, the fuel can be supplied to the engine either from:

1. Directly from sub-base fuel tank located under the generating set.
2. An intermediate daily service tank located within the plant room or generator enclosure, which is automatically refilled from a bulk storage tank
3. Directly from the bulk storage tank, provided that the outlet connection from this tank is at least 500 mm higher than the base on which the generator is mounted.

It is very important that the fuel oil purchased for use in any engine be as clean and water-free as possible. Dirt in the fuel can clog injector outlets and ruin the finely machined precision parts in the fuel injection system. Water in the fuel will accelerate corrosion of these parts.

### 5.2. Fuel Oil Recommendations

The following fuel oil specification is typical

#### Fuel oil Recommended Physical Properties Specifications.

|  |  |
|--|--|
| Viscosity<br>(ASTM D445)               | 1,3 to 5,8 centi strokes<br>(1,3 to 5,8 mm per second) at<br>40°C (104°F)                  |
| Cetane Number<br>(ASTM D613)           | 40 Minimum above 0°C (32°F)<br>45 Minimum below 0°C (32°F)                                 |
| Sulphur Content<br>(ASTM D129 or 1552) | Not to exceed 0,5 mass percent   |
| Water and Sediment<br>(ASTM D1796)     | Not to exceed 0,05 volume<br>percent   |
| Density<br>(ASTM D287)                 | 42 to 30° API gravity at 60°F<br>(0,816 to 0,876 g/cc at 15°C)                             |
| Cloud Point<br>(ASTM D287)             | 6°C (10°F) below lowest ambient<br>temperature at which the fuel is<br>expected to operate |

|                            |   |
|----------------------------|---|
| Ash<br>(ASTM D482)         | Not to exceed 0,02 mass percent<br>(0,05 mass percent with<br>lubricating oil blending) |
| Acid Number<br>(ASTM D664) | Not to exceed 0,1 Mg KOH per<br>100 ML  |
| Lubricity                  | 3100 grams or greater   |

### Diesel Fuel Property Definition

**Ash** - Mineral residue in fuel. High ash content leads to excessive oxide build up in the cylinder and/ or injector:

**Cetane Number** - Ignitability of fuel. The lower the cetan number; the harder it is to start and run the engine. Low cetane fuels ignite later and burn slower. This could lead to explosive detonation by having excessive fuel in the chamber at the time of ignition. In cold weather or with prolonged low loads, a higher cetane number is desirable.

**Cloud and Pour Points** - The pour point is the temperature at which the fuel will not flow. The cloud point is the temperature at which the wax crystals separate from the fuel.

The pour point should be at least 6°C ( 10°F ) below the ambient temperature to allow the fuel to move through the lines. The cloud point must be no more than 6°C ( 10°F ) above the pour point so the wax crystals will not settle out of the fuel and plug the filtration system.

**Sulphur** - Amount of sulphur residue in the fuel .The sulphur combines with the moisture formed during combustion to form sulphuric acid.

**Viscosity** - Influences the size of the atomized droplets during injection. Improper viscosity will lead to detonation, power loss and excessive smoke.

Fuels that meet the requirements of ASTM or 2.0 diesel fuels are satisfactory with fuel systems.

### 5.3. Base Fuel Tank

Up to 600 kVA generating sets can be supplied with or without base fuel tanks, and the room height allows for this feature.

Recommended room layout drawings incorporate base fuel tanks on the generators

This provides a self contained installation without the additional of external fuel lines, trenches and fuel transfer pumps. Generators with base tanks are delivered fully connected and ready to run.

#### 5.4. Bulk Storage Tanks

The purpose of the fuel-supply system is to store an adequate quantity of fuel to suit the application for which the system is intended. The bulk storage tanks should be sized accordingly.

The filling of the tanks will be by means of a fill connection housed in a suitable lockable cabinet located so as to permit easy access by delivery tanker. This cabinet may also house a contents gauge and an overflow alarm connected to the float switch inserted into a manhole on the tank.

#### 5.5. Without Intermediate Fuel Tank (Fig. 5.1.)

The simplest arrangement would be to supply the engine directly from the bulk storage tank and return the injector spill directly to this tank. A typical arrangement for this is shown in Fig. 5.1.

The principle limitations of this method are: In order to gravity feed the engine, the outlet from the bulk storage tank must be a minimum of 600 mm above the generator plinth level;

The pressure drop of the spill return pipe work must not exceed that detailed in the Engine Data sheet. The supply pipe work from the bulk storage tank to the engine must be sized to allow the total volume of fuel required by the engine to flow under gravity.

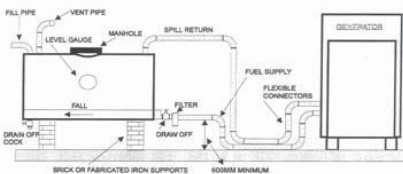

Fig. 5.1. Without Intermediate Fuel Tank

#### 5.6. With Intermediate Fuel Tank (Fig. 5.2)

Where, due to site constraints, it is not possible to supply the engine direct from the bulk tank an intermediate tank can be located within the plant room/generator enclosure which supplies fuel directly to the engine.

This type of system can be further enhanced by the addition of the following optional items of equipment:

1. An automatic duplex fuel transfer pump and primary filter system arranged to start the standby pump should the duty pump fail. The transfer pump(s) must be sized to cater for the total fuel required by the engine, i.e. fuel consumed and the spill return volumes (Fig. 5.2.);
2. A fusible link operated dead weight drop valve designed to cut off the supply of fuel to the intermediate tank and to transmit a signal in the vent of fire;
3. A fusible link operated dump valve, arranged to dump the contents of the local tank back into the bulk tank in the event of a fire within the generator enclosure.

The connection details for these additional items of equipment are indicated. See Fig. 5.2.

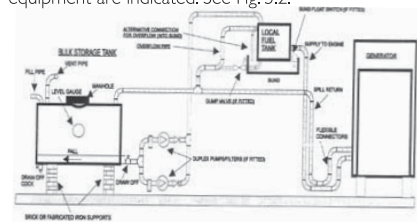

Fig. 5.2. With Intermediate Fuel Tank

#### 5.7. Daily Service Fuel Tank

Separate daily service tank can be 500 litres, 1250 litres or 2000 litres and a transfer system arranged to automatically feed from the bulk storage tank electric motor driven pump(s) operating from signals from a level sensing float switch. Fuel tanks should not be made from galvanized iron as diesel fuel oil reacts against zinc.

A vent pipe should be extended to the highest point of the fuel system installation. The diameter of the pipe should at least match that of the fill connection. Provision should be made to prevent the ingress of dirt. The overflow from the daily service intermediate tank can either be:

1. Piped directly back to the bulk storage tank;
2. Piped into the bund of the intermediate tank with a bund level alarm system arranged to cut off the fuel transfer pump system on detection of a spillage;
3. Piped to overflow into the bunded area.

The feed connection on the tank should not be lower than 600 mm above the level on which the engine sits in order to maintain a gravity feed to the engine. When the intermediate tank is located at a lower level than the bulk storage tank it is essential that a solenoid valve be incorporated into the transfer line. All final connections to the engine should be in flexible hose to restrict vibration transmission through the pipe.

### 5.8. Determining Pipe Sizes

Minimum pipe sizes are determined by the size of the inlet to the fuel transfer pump. The pipe inner diameter must be at least as large as the transfer pump inlet. If the piping must carry the fuel over long distances, the pipe size must be increased. An auxiliary transfer pump at the tank outlet may also be needed to avoid high suction pressure within the piping. In all cases, excessive fuel line suction pressures must be avoided. At high suction pressures the fuel vaporizes in the piping and the fuel supply to the engine will be decreased. When sizing piping, always remember to account for pressure drop across filters, fittings and restriction valves. A flex connector must be added to isolate the engine vibration from the fuel piping. If this vibration is not isolated, the piping could rupture and leak. The flexible connector must be as close to the engine transfer pumps as possible. Any expanse of exposed piping must be properly supported to prevent piping ruptures. Use pipe hangers to isolate vibration from the system. Exposed fuel piping must never run near heating pipes, furnaces, electrical wiring or exhaust manifolds. In the area around the piping

is warm, the fuel lines should be insulated to prevent the fuel and piping from picking up any excess heat. All pipes should be inspected for leaks and general condition, including cleanliness before installation. Back flush all lines to the tank before start-up to avoid pulling excess dirt into the engine and fuel piping system. After installation, the air should be bled from the fuel system. A petcock should be included at some high point in the system to allow air removal.

Use plugged tees, not elbows, to make piping bends. This will allow for cleaning by removing the plugs and flushing out the lines. All threaded pipe fittings must be sealed with a suitable paste.

Caution: Do not use tape to seal fuel line fittings. Pieces of tape could shear off and jam in the pump or injectors.

### 5.9. Fuel Return Lines

Fuel return lines take the hot excess fuel not used in the engine cycle a way from the injectors and back to either the fuel storage tank or the day tank. The heat from the excess fuel is dissipated in the tank.

Caution: Never run a fuel return line directly back to the engine fuel supply lines. The fuel will overheat and break down.

The fuel return lines should always enter the storage or day tank above the highest fuel level expected. This statement is true for all Cummins powered engines with the PT fuel system (NT, K range). However with sets using the B series, C series engines drain lines for fuel will cause siphoning back through the supply line and result in hard starting if installed above the fuel level. The fuel return line should never be less than one pipe size smaller than the fuel supply line.

#### WARNING!

- The fuel must be clean and must not contain any water
- Fuel pipes must be made of black pipe, not galvanized pipe.
- When the engine stops, there should not be any gravitational free flow in the fuel pipes towards the engine.



- The fuel temperature is a critical factor for appropriate working conditions of the engine. Fuel temperature above 71°C, due to expansion of the fuel, will decrease the engine output power.

- In fuel system line, using the water filter separators will prevent the injectors and fuel pump and it useful for healthy working of the engine.

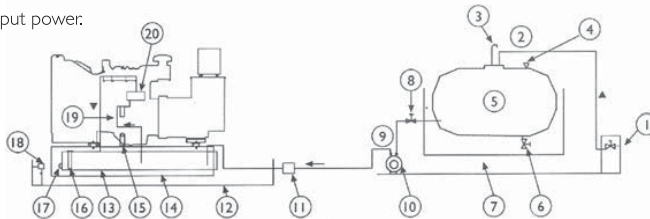

Figure 5.3. Typical fuel installation using a base tank fed from a bulk tank

1. Fill cabinet with overflow alarm and gauge
2. Tank fill line
3. Vent line
4. Contents gauge
5. Bulk storage tank
6. Sludge drain
7. Bund tank
8. Outlet valve
9. Supply line to day tank
10. Electric fuel transfer pump

11. Electrical fuel shut off valve
12. Optional band
13. Day tank incorporated in base frame
14. Float Control switches
15. Manual fill and vent
16. Level gauge
17. Drain
18. Leakage alarm unit (optional)
19. Fuel filter
20. Engine fuel pump

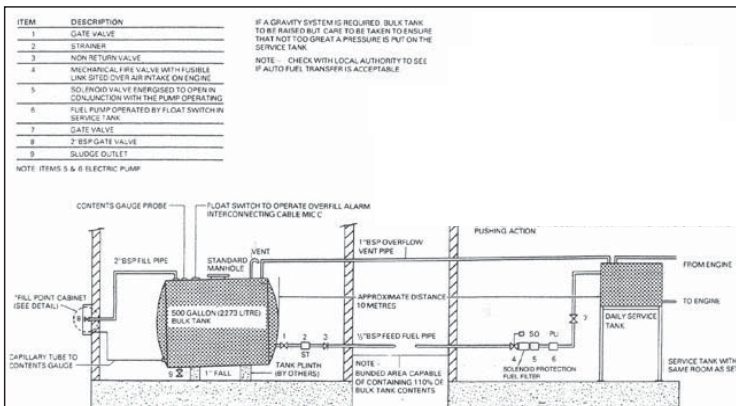

Figure 5.4. Suggested Installation for Bulk and Set Tanks

| Generating Set Stand by Power | Maximum Fuel Pipe Length (m) | Maximum Vertical Height (m) | Maximum Pipe Fittings Quantity (m) | Recommended Pipe Diameter (inch) |
|-------------------------------|------------------------------|-----------------------------|------------------------------------|----------------------------------|
| 40 - 800                      | 6                            | 0,9                         | 6                                  | 1"                               |
| 800 - 1500                    | 6                            | 0,9                         | 6                                  | 1 1/2"                           |
| 1500 - 2200                   | 6                            | 0,9                         | 6                                  | 2"                               |

Table 5.1 Recommendations for fuel piping

## 6. WATER TREATMENT

### 6.1. General

The engine cooling system is subject to rust and cavitation attacks. To minimize the severity of this condition an anti-corrosive agent can be added to totally clean and limp coolant water.

An antifreeze solution is also required to prevent freezing of the coolant in the cold weather.

### 6.2. Engine Coolant

Water for coolant should be clean and free from any corrosive chemicals such as chlorides, sulphates and acids. It should be kept slightly alkaline with a pH value in the range 8.5 to 10.5

Generally, any water which is suitable for drinking can be used, with treatment as described below.

#### Protection against corrosion

Supplemental Coolant Additive is required to protect the cooling system from fouling, solder blooming and general corrosion.

The use of antifreeze is also recommended as DCA4 concentrations are dependent upon the presence of antifreeze. Antifreeze also interacts with DCA4 to provide greater corrosion and cavitation protection.

#### Procedure for Treating Coolant

1. Add the required amount of water to mixing container and dissolve in the required quantity of DCA.
2. Add the required amount of antifreeze, if used, to the water solution and mix thoroughly.
3. Add the coolant to the cooling system

#### Cold Weather Protection

Antifreeze must be added to the coolant where there is any possibility of freezing to protect the engine from damage due to coolant freezing.

A 50% antifreeze / 50% water mixture is recommended because DCA4 concentrations are dependent upon the presence of antifreeze. The dosage of DCA4 must be increased to higher concentration if antifreeze is not added to the coolant. A low-silicate antifreeze is recommended.

### 6.3. Engine Warming

Where thermostatically controlled immersion heaters operating from the mains supply are fitted in cooling system these maintain the temperature of the coolant in cold weather:

A heater alone, fitted in the radiator will not be adequate for starting or preventing freezing, so an antifreeze mixture should be used.

## 7. EXHAUST SYSTEM

### 7.1. Sizing

An exhaust system should be designed to dispel the exhaust gases to atmosphere at the nearest convenient point in an installation. The length of the run and the number of changes in direction should be kept to a minimum to avoid exceeding optimum.

The calculation of the effect on the back pressure is based upon the restriction through the straight lengths of pipe, the bends and the silencers. The smaller the bore of the pipe, the greater its length and the more times it changes its direction, the greater is its resistance to flow.

The back pressure limit for most Cummins engines is 3 ins Hg (76 mm Hg)

Take an estimate of the size of the pipe by starting with the bore of the exhaust flange off the manifold and increasing the size by 1" for each 20 ft length or 3 x 90° bends.

### 7.2. Routing

Once the final size and route of the pipe work and the silencer have been established, the exhaust route can be determined, taking into account the following factors:

A flexible bellows unit must be fitted on the engine connection to allow the engine to move on its mountings; If the silencer is to be located within the plant room, due to its physical size and weight need to be supported from the floor;

It may be necessary to install expansion joints at each change of direction to compensate for the thermal growth in the pipe during operation;

The inner radius of a 90° bend should be 3 times the diameter of the pipe; Fig. 7.1.

The primary silencer should be mounted as close as possible to the engine;

The termination point should not be directed at combustible materials/structures, into hazardous atmospheres containing flammable vapors, where there is a danger that the gases will re-enter the plant room through the inlet air vent, or into any opening to other buildings in the locality.

All rigid pipe work should be installed in such a manner that the engine's exhaust outlet is not stressed. Pipes should be routed so that they are supported by fixtures to the building fabric or by existing structural steelwork where such methods are acceptable;

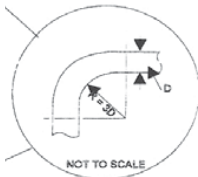

Fig. 7.1. Exhaust bend and radius

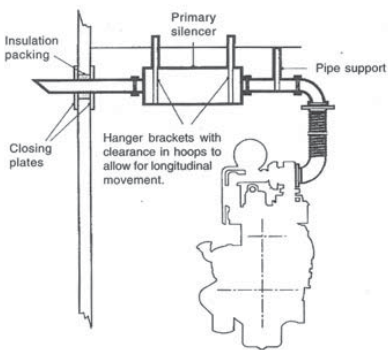

Fig. 7.2. Exhaust system

## 8. LUBRICATING OIL

Oil system of diesel engine is one of the most important elements of the engine. Correctly made engine overhaul ( this subject includes oil change periods, filter change periods, paying attention about selecting the true type of oil ) prolongs the life cost of the engine.

### 8.1. Oil Performance Properties

The American Petroleum Institute (API) the American Society for Testing and Materials (ASTM) and Society of Automotive Engineers (SAE) has developed and preserved a system in order to classify the lubrication oils for their performance categories.

### 8.2. Lubrication Recommendations for Engine

Aksa recommends that high quality multi grade SAE 15W/40 high service engine oil in diesel engines are used. At ambient temperatures above -15 °C is 15W/40. The minimum API oil quality levels recommended for use is CH / CI-4, CH or CI-4 can be used in areas where CF4 oil is not yet available, but the oil interval must be reduced API CA, CB, CC, CD, CE, CG4 categories not recommended, do not use.

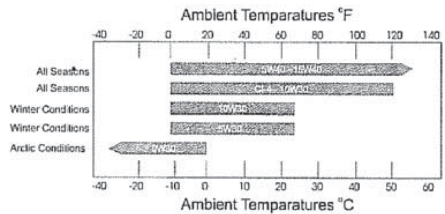

Figure: 8.1. Recommended SAE Oil Viscosity Grades vs. Ambient Temperatures

| Generatin Set |                         |                 | Fuel Consumption<br>Full Load<br>L/h | Fuel Tank<br>Capacity<br>Liter | Coolant Capacity<br>Liter | Oil capacity<br>Liter | Oil Specifications<br>Not; Lubricating oil viscosity level will be chosen<br>from Table 8.1. according to the ambient<br>temperature |
|---------------|-------------------------|-----------------|--------------------------------------|--------------------------------|---------------------------|-----------------------|--|
| Model         | Stand<br>Power<br>(kVA) | Engine<br>Model |                                      |                                |                           |                       |  |
| APD 20 A      | 20                      | A4CRX22         | 5                                    | 95                             | 10                        | 10                    | API CH<br>API CI - 4<br>API CF4  |
| APD 25 A      | 25                      | A4CRX25         | 6,2                                  | 95                             | 11                        | 10                    |  |
| APD 30 C      | 30                      | 4B3,9-G2        | 6,7                                  | 145                            | 19                        | 11                    |  |
| APD 33 A      | 33                      | A4CRX25T        | 7,6                                  | 95                             | 11                        | 10                    |  |
| APD 40 A      | 40                      | A3CRX32T        | 10,5                                 | 82                             | 18                        | 11                    |  |
| APD 43 C      | 43                      | 4BT3,9-G2       | 9,3                                  | 145                            | 19                        | 11                    |  |
| APD 50 A      | 50                      | A4CRX47         | 11,5                                 | 145                            | 18                        | 14                    |  |
| APD 70 A      | 70                      | A4CRX46T        | 17                                   | 145                            | 19                        | 14                    |  |
| APD 90 A      | 93                      | A4CRX46TI       | 22                                   | 195                            | 26                        | 14                    |  |
| APD 110 C     | 110                     | 6BT5,9-G2       | 23                                   | 195                            | 25                        | 16,5                  |  |
| APD 125 A     | 125                     | A6CRX65TI       | 28                                   | 300                            | 54                        | 16                    |  |
| APD 145 C     | 145                     | 6BTAA5,9-G2     | 30                                   | 195                            | 27                        | 16,5                  |  |
| APD 150 A     | 150                     | A6CRX69TI       | 32,5                                 | 300                            | 54                        | 16                    |  |
| APD 200 C     | 200                     | 6CTA8,3-G2      | 40                                   | 320                            | 36                        | 20                    |  |
| APD 250 A     | 750                     | A6CRX98TI       | 52                                   | 380                            | 46                        | 24                    |  |
| APD 275 C     | 275                     | 6LTAA8,9-G2     | 54                                   | 420                            | 35                        | 24                    |  |
| APD 330 A     | 330                     | A6CRX129TI      | 69                                   | 525                            | 51                        | 28                    |  |
| APD 350 C     | 350                     | NTA855-G1B      | 68                                   | 450                            | 70                        | 38                    |  |
| APD 385 C     | 385                     | NTA855-G2A      | 72                                   | 450                            | 70                        | 38                    |  |
| APD 1000 C    | 1000                    | KTA38-G2A       | 191                                  | 1250                           | 280                       | 114                   |  |
| AJ 1375       | 1375                    | A12CRX715TI     | 258                                  | 2000                           | 580                       | 200                   |  |
| APD 1425 M    | 1425                    | S12R-PTA        | 261                                  | 2000                           | 335                       | 180                   |  |
| APD 1540 M    | 1540                    | S12R-PTA2       | 289                                  | 2000                           | 305                       | 180                   |  |
| AJ 1600       | 1600                    | A12CRX 732TI    | 296                                  | 2000                           | 470                       | 250                   |  |
| APD 1650 M    | 1650                    | S12R-PTAA2      | 308                                  | 2000                           | 317                       | 180                   |  |
| APD 1915 M    | 1915                    | S16R-PTA        | 357                                  | 2000                           | 350                       | 230                   |  |
| APD 2100 M    | 2100                    | S16R-PTA2       | 394                                  | 2000                           | 445                       | 230                   |  |
| APD 2225 M    | 2225                    | S16R-PTAA2      | 407                                  | 2000                           | 400                       | 230                   |  |

Table 8.1. Fuel consumption and coolant, fuel and lubricating oil capacities and lubricating oil specifications.

## 9. ELECTRIC STARTING SYSTEMS

Electric starting systems are generally used on all gen-sets. The power source for electric starting systems is a 12 or 24 VDC battery system. The starting voltage is determined by engine size, 24 VDC being used for larger engines to reduce starting current and hence cable size. Control of starting is via a start solenoid which is controlled by the gen-set control system.

### 9.1. Battery Systems

Batteries are of two types - lead acid and NiCad. Lead acid batteries are generally used, being the least expensive. NiCad batteries are used where longer life, etc., is required.

### 9.2. Maintenance Batteries

#### Warning

- Do not smoke or allow sparks, flames or other sources of ignition around batteries. Hydrogen gas generated by charging batteries is explosive.
- Wear an acid resistant apron and face shield or goggles when servicing the battery. If electrolyte is spilled on skin or clothing, flush immediately with large quantities of water.
- Take out the metallic things in your wrist and protect your wrist and hand.
- Disconnect the battery negative (earth) lead first and reconnect last.
- Always ensure that battery charging is carried out in a well ventilated area.

The starting batteries should be located as close as possible to the generating set while still being accessible for servicing. This will prevent electrical losses

### 9.3. Battery Maintenance

- Keep the top of the battery and its terminals clean.
- Cover the battery terminals and its connections with Vaseline.
- Tighten the terminals but not tighten it hardly.
- Control the electrolyte level periodically. It must be 10 mm above the plates.
- Control the abrasion in the charge alternator belt and check periodically the belt tension according to producer' recommendation.

- Ensure that your battery is not uncharged.

### 9.4. Maintenance Free Batteries

Ensure that all battery connections are correct and batteries are always charged. After that there is not any procedure for this batteries.

### 9.5. Starting Aids

It is customary to maintain coolant temperatures above 40°C min. To promote quick starting on an emergency generating plant. Thermostatically controlled immersion heaters, deriving their supply from the primary source of power are fitted in the engine cooling system to provide this heating.

## 10. ELECTRICAL CONNECTION

Only full qualified and experienced electrical technicians should carry out electrical installation, service and repair work.

#### Warning:

- Make electrical connections in compliance with relevant Electrical Codes, Standards or other requirements.

### 10.1. Cabling

Due to movement of generating sets on their vibration mounts, the electrical connection to the set should be made with flexible cable.

The cable must be suitable for the output voltage of the generating set and the rated current of the set. In determining the size, allowances should be made for ambient temperature. Method of installation, proximity of other cables. etc.

All connections should be carefully checked for integrity. Current carrying capacity of power cables that will be given in table 10.1 and the cable cross sections which must be used according to the generating set power has been given in table 10.2. On the other hand, there is a one more important point while cable cross sections are being selected. If the distance between load and generator is too length, voltage falling at the load side can be too much at the transient current duration. The voltage drop across a cable can be determined as follows:

$$e = \frac{\sqrt{3} \times L \times I \times (R \cos\phi + X \sin\phi)}{1000}$$

e = Voltage drop (V)

I = Rated current (A)

L = Length of conductors (m)

R = Resistance ( $\Omega$ /km to VDE 0102)

X = Reactance ( $\Omega$ /km to VDE 0102)

### 10.2. Protection

The cables connecting the generating set with the distribution system are protected by means of a circuit breaker to automatically disconnect the set in case of overload or short circuit. (Manual models only)

### 10.3. Loading

When planning the electrical distribution system, it is important to ensure that a balanced load is presented to the generating set. If loading on one phase is substantially higher than the other phases it will cause over heating in the alternator windings, imbalance in the phase output voltage and possible damage to sensitive 3 phase equipment connected to the system. Ensure that no individual phase current exceeds the current rating of the generating set. For connection to existing distribution system, it may be necessary to reorganize the distribution system to ensure these loading factors are met.

### 10.4. Power Factor

The power factor ( $\cos\phi$ ) of the connected load should be determined. Power factors below 0,8 lagging (inductive) can over load the generator. The set will provide its kilowatt rating and operate satisfactorily from 0,8 lagging to unity power factor (1.0) Particular attention must be given to installations with power factor correction equipment such as capacitors to ensure that a leading power factor is never present. This will lead to voltage instability and may result in damaging over voltages. Generally whenever the generating set is supplying the load any power factor correction equipment should be switched off.

| Cable Section mm <sup>2</sup> | Soil          | 25°C at Air   | 40°C at Air   |               |          |
|-------------------------------|---------------|---------------|---------------|---------------|----------|
|                               | Multiple Core | Multiple Core | Multiple Core | Multiple Core | HO07RN-F |
| 2,5                           | 36            | 25            | 22            | 25            | 21       |
| 4                             | 46            | 34            | 30            | 33            | 28       |
| 6                             | 58            | 44            | 38            | 42            | 36       |
| 10                            | 77            | 60            | 53            | 57            | 50       |
| 16                            | 100           | 80            | 71            | 76            | 67       |
| 25                            | 130           | 105           | 94            | 101           | 88       |
| 35                            | 155           | 130           | 114           | 123           | 110      |
| 50                            | 185           | 160           | 138           | 155           | 138      |
| 70                            | 230           | 200           | 176           | 191           | 170      |
| 95                            | 275           | 245           | 212           | 228           | 205      |
| 120                           | 315           | 285           | 248           | 267           | 245      |
| 150                           | 355           | 325           | 283           | 305           | 271      |
| 185                           | 400           | 370           | 322           | 347           | 310      |
| 240                           | 465           | 435           | 380           | ....          | ....     |

**Table 10.1.** Current carrying capacity of power cables (PVC - isolated YVY, NYV, 0,6/1 kV, VDE and TSE norms)

### 10.5. Grounding / Earthing Requirements:

The frame of the generating set must be connected to an earth ground. Since the set is mounted on vibration isolators, the ground connection must be flexible to avoid possible breakage due to vibration. Ground connection cables or straps should have at least full load current carrying capacity and meet applicable regulations.

### 10.6. Insulation Test:

Before starting the generating set after installation, test the insulation resistance of the windings. The Automatic Voltage Regulator (AVR) should be disconnected and the rotating diodes either shorted out with temporary links or disconnected. Any control wiring must also be disconnected.

A 500 V Megger or similar instrument should be used. Disconnect any earthing conductor connected between neutral and earth and megger an output terminal to earth.

The insulation resistance should be in excess of 1M $\Omega$  to earth. Should the insulation resistance be less than 1M $\Omega$  winding must be dried out.

| Generating Sets |                     | Full Load current at U=400 Vac (A) | Cable current capacity at 40°C ambient (A) | Cable section YV Single core for each phase (mm <sup>2</sup> ) |
|-----------------|---------------------|------------------------------------|--|--|
| Model           | Standby Power (kVA) |                                    |  |  |
| APD 20 A        | 20                  | 28                                 | 33   | 4  |
| APD 25 A        | 25                  | 36                                 | 42   | 6  |
| APD 30 C        | 30                  | 43                                 | 57   | 10   |
| APD 33 A        | 33                  | 47                                 | 57   | 10   |
| APD 40 A        | 40                  | 58                                 | 76   | 16   |
| APD 43 C        | 43                  | 62                                 | 76   | 16   |
| APD 50 A        | 50                  | 72                                 | 101  | 25   |
| APD 70 A        | 70                  | 101                                | 123  | 35   |
| APD 90 A        | 93                  | 134                                | 155  | 50   |
| APD 110 C       | 110                 | 158                                | 191  | 70   |
| APD 125 A       | 125                 | 180                                | 228  | 95   |
| APD 145 C       | 145                 | 209                                | 267  | 120  |
| APD 150 A       | 150                 | 216                                | 267  | 120  |
| APD 200 C       | 200                 | 289                                | 382  | 2x70   |
| APD 250 A       | 250                 | 361                                | 456  | 2x95   |
| APD 275 C       | 275                 | 397                                | 456  | 2x95   |
| APD 330 A       | 330                 | 476                                | 534  | 2x120  |
| APD 350 C       | 350                 | 505                                | 610  | 2x150  |
| APD 385 C       | 385                 | 556                                | 684  | 3x95   |
| APD 1000 C      | 1000                | 1445                               | 1830                                       | 6x150  |
| AJ 1375         | 1375                | 1986                               | 2440                                       | 8x150  |
| APD 1425 M      | 1425                | 2056                               | 2440                                       | 8x150  |
| APD 1540 M      | 1540                | 2222                               | 2745                                       | 9x150  |
| AJ 1600         | 1600                | 2309                               | 2745                                       | 9x150  |
| APD 1650 M      | 1650                | 2381                               | 2745                                       | 9x150  |
| APD 1915 M      | 1915                | 2764                               | 3355                                       | 11x150   |
| APD 2100 M      | 2100                | 3031                               | 3660                                       | 12x150   |
| APD 2225 M      | 2225                | 3247                               | 3660                                       | 12x150   |

Table 10.2. Recommended single core cable cross section at 40 °C ambient.

## 11. ACOUSTIC SILENCING

Control of generating set noise is becoming very important in most installations. There is range of components available to control the noise level.

### WARNING!

Ear protection must be worn when operating or working around an operating generating set.

#### 11.1. Exhaust Silencers:

As discussed in Section 3.10, the exhaust silencer will decrease sound level from the engine.

#### 11.2. Canopies:

Section 4.2, discusses sound attenuating canopies that lower the noise level of the entire generating set.

#### 11.3. Other Sound Attenuation:

For installation in buildings there are other types of equipment such as acoustic louvers, splitter vents and fan silencers, as well as sound absorbing wall coverings, that can be used to reduced the noise levels of generating sets.

## 12. TOWING (Mobile Generating Sets)

### 12.1. Preparing to Tow:

Inspect all components of the coupling equipment on the towing vehicle and the generating set for defects such as excessive wear, corrosion, cracks, bent metal, or loose bolts.

Inspect tyres for condition and proper inflation. Check that all tail lights, if equipped, are operating properly and that all reflectors are clean and functional.

### 12.2. Towing:

Whenever towing a mobile generating set, remember that manoeuvrability and stopping distance will be affected by the weight of the trailer.

### WARNING

! When mobile generating set, observe all Codes, Standards or other regulations and traffic laws. These include those regulations specifying required equipment and maximum and minimum speeds.

! Do not permit to ride on the mobile generating set. Do not permit personnel to stand or ride on the drawbar or to stand or walk between the generating set and towing vehicle.

! Avoid gradients and avoid potholes, rocks or other obstructions and soft or unstable terrain. ! Ensure the area behind and under the mobile set is clear before reversing.

### 12.3. Parking:

Park the set on a dry level area that can support it's weight. If it must be located on a slope, park it across the grade so that it does not tent to roll downhill. Do not park the set on grades exceeding 15°.

### 13. STORAGE OF THE GENERATOR

#### 13.1. Storage

- Store the generator in a dry frost-free room which is well ventilated.
- Run the engine regularly, e.x. once a week until it is warmed up. If this is in possible, extra pre cautions must be taken.
- Consult the engines operator manual.

#### 13.2. Alternator Storage:

When an alternator is in storage, moisture tends to condense in the windings. To minimize condensation, store the generating set in a dry storage area. If possible use space heaters to keep the windings dry. After removing the generating set from storage, perform an insulation check as discussed in Section 10.6.

#### 13.3. Battery Storage:

While the battery is stored, it should receive a refreshing charge every 8 weeks up to a fully charged condition.

- Keep the inlet opening open.
- Make sure that the generating set can easily take air from the environment.
- Check the battery connection cables. Take care to tighten the loosened battery terminals with spanner and, cover with special substance and keep clean in order to avoid oxidation.
- Open the battery caps and check the liquid level in the cells for maintenance type battery. Add distilled water, if necessary, so as to be 1 cm higher than the separation. Never fill the cells with tap water, acid water or acid.
- Check if the circuit breaker outlet switch is in OFF position.
- Make sure that the emergency stop button is not pressed.

### 14. GENERAL PRECAUTIONS AND CONTROLS WHICH MUST BE DONE BEFORE STARTING UP THE GENERATING SET.

- Make a general visual inspection on the engine and alternator. Check if there is any breakage, crack, indentation, leakage or looseness. Never operate the generating set before removing any fault, if any.
- Take out foreign materials such as keys, tools, cleaning wool, papers etc. on the engine and the alternator.
- Check the fuel level in day tank. Refill with fuel if it is low.
- Check the oil level on the dipstick. Refill with an appropriate oil if it is low. Oil level normally must be close to the maximum level line.
- Look at the water level by opening the radiator tap. If it is inadequate add more water. Water level must be 30 mm lower than the water filling neck.
- Engine cooling water must include antifreeze according to the coolest weather conditions in the area. A mixture of 50% antifreeze and 50% water provides a good protection in all area.
- Inspect the radiator air outlet hood, open if clogged and clear away all obstructions in front of the air outlet.
- Check the air filter gauge. Clean or replace air filter, if necessary.



## 14.1. ICONS and LCD IDENTIFICATION

### 14.1.1. Push Buttons

| Display | Description | Display | Description     | Display | Description                         |
|---------|-------------|---------|-----------------|---------|-------------------------------------|
|         | Stop/Reset  |         | Configure / log |         | Auto mode                           |
|         | Scroll      |         | Test mode       |         | Start (when in Manual or Test mode) |
|         |             |         | Manual mode     |         |                                     |

### 14.1.2. Status / Measurement Units

| Display | Description                        | Display | Description            | Display    | Description       |
|---------|------------------------------------|---------|------------------------|------------|-------------------|
| L1      | Phase                              | L2      | Phase                  | L3         | Phase             |
| L1- N   | Phase - Neutral                    | L2- N   | Phase - Neutral        | L3- N      | Phase -Neutral    |
| L1- L2  | Phase - Phase                      | L2- L3  | Phase - Phase          | L3- L1     | Phase - Phase     |
| BAR     | Pressure                           | KPa     | KPa Oil Pressure Units | PSI        | Pressure          |
| V       | Voltage                            | °F      | Temperature            | Hz         | Frequency         |
| A       | Amperes                            | °C      | Temperature            | RPM        | Speed             |
| kW      | KiloWatts                          | kVA     | Apparent power         | $\cos\phi$ | KW divided by kVA |
|         | Hours Run                          |         | AC                     |            | Generator         |
|         | Timer in progress                  |         | DC                     |            | Mains (Utility)   |
|         | Configuration mode active          |         | Fuel level             |            | Event log         |
|         | Panel locked by configurable input |         |                        |            |                   |

### 14.1.3. Alarm Indications

| Display | Description          | Display | Description                           | Display | Description          |
|---------|----------------------|---------|---------------------------------------|---------|----------------------|
|         | Warning Alarm        |         | Shutdown Alarm                        |         | Electrical Trip      |
|         | Fuel                 |         | Low Oil Pressure                      |         | High Current Warning |
|         | Charge Fail          |         | High Coolant Temperature              |         | Over Voltage (AC)    |
|         | Emergency Stop       |         | Fail to start (Over-crank)            |         | Under Voltage (AC)   |
|         | Over Voltage (DC)    |         | Over-speed                            |         | Over frequency       |
|         | Under Voltage (DC)   |         | Under-speed                           |         | Under frequency      |
|         | Auxiliary Indication |         | Auxiliary Alarm (Warning or Shutdown) |         |                      |

## 15. GENERAL PRECAUTIONS AND CONTROLS WHICH MUST BE DONE AFTER STARTING UP THE GENERATING SET

- Check for any abnormal noise or vibration on the generating set.
- Check if the exhaust system has any leakage.
- Monitor the generating set operation by means of the control module LCD display. Check the engine temperature and oil pressure

Oil pressure must reach the normal value 10 seconds after the generating set operation.

- Monitor the generating set outlet voltage and frequency by means of the control module LCD display. Check the voltage, if the voltage between phases is 400 V. and between phase and neutral is 230 V. Check that the frequency is 51 - 52 Hz on generating sets with mechanical governors and 50 Hz on generating sets with electronic governors.
- If an engine block water heater is not available, run the generating set at no-load for 8 minutes and when the engine warm than apply on load (for manual models)

Apply load to the generating set as follows:

- Set the alternator outlet circuit breaker on the panel to ON position.
- Set the load circuit breakers (or fuses) on the distribution panel to ON position one by one. This way, the generating set cannot be suddenly put under full load. Otherwise, the engine stalling or alternator winding insulation of formation or burning can occur.
- Set the alternator outlet circuit breaker on the circuit to OFF position before stop the generating set.
- Continue to run the unloaded engine for purpose of cooling period for 5 minutes and then stop.
- Never operate the generating set before removing any fault, if any.

## 16. CONTROL PANELS

Control, supervision and protection panels are mounted on the generator base frame.

### 16.1. Control System P72 Panel Specifications Equipments:

- DSE 720, Automatic Mains Failure module
- Static battery charger
- Emergency stop push button

#### DSE 720 Module Features

- To monitoring AC mains supply
- Automatic controls generating set, start and stop
- Provide signal to change over switch
- Scrolling digital LCD display
- Front panel configuration of timers and alarm trip points
- Easy push button control  
STOP/RESET - MANUAL - AUTO - TEST - START

#### Metering via LCD display

- Generator Volt (L - N)
- Generator Ampere (L1, L2, L3)
- Generator Frequency (Hz)
- Mains Volt (L - L / L - N)
- Engine cooling temperature
- Engine oil pressure
- Engine speed
- Engine hours run
- Engine battery volt

#### LED Display

- Generator Available
- Generator on Load
- Mains Available
- Mains on Load

## 16.2. Control System P 732

Equipments:

- DSE 7320, Automatic Mains Failure module
- Static battery charger
- Emergency stop push button

### DSE 7320 Module Features

- To monitoring AC mains supply
- Automatic controls generating set, start and stop
- Provide signal to change over switch
- Scrolling digital LCD display
- Remote communication via RS232 port or RS 485 mod bus output.
- Event logging of shutdown alarms.



**Figure 16.1.**

DSE 7320

Description of Controls  
on DSE 7320 module

- Front panel configuration of timers and alarm trip points

- Easy push button control

STOP/RESET - MANUAL - AUTO - TEST - START

- NAVIGATION

### Metering via LCD display

- Generator Volts (L-L / L - N)
- Generator Ampere (L1, L2, L3)
- Generator Frequency (Hz)
- Generator kVA
- Generator kW
- Generator Cos  $\phi$
- Mains Volt (L - L / L - N)
- Mains Frequency (Hz)
- Engine cooling temperature ( $^{\circ}$ C &  $^{\circ}$ F)
- Engine oil pressure (PSI & Bar)
- Engine speed (RPM)
- Engine hours run
- Plant battery volt
- Generator, kWh, kVAh, kVArh

### Multiple Alarms

- Under / Over generator volts; Pre-alarm and Shutdown
- Under / Over generator frequency Pre-alarm and Shutdown
- Under / Over mains volts
- Under / Over mains frequency
- Over current; Shutdown
- Low oil pressure; Pre-alarm and Shutdown
- High engine temperature; Pre-alarm and Shutdown
- Under/over speed; Shutdown
- Low coolant level; Shutdown
- Fail to start; Shutdown
- Fail to stop; Warning
- Low/High battery volts; Warning
- Charge fail; Warning
- Emergency stop; Shutdown
- Can Data Fail; Shutdown
- Can ECU Fail; Pre-Alarm and Shutdown
- Phase rotation

### The Event Log

7320 control module maintains a log the last 50 shutdown alarms to enable the operator or engineer to view the past alarms history.

## 11.5. Control System P 602 Panel Specifications

Control, supervision and protection panel is mounted on the generator set base frame.

### Equipments:

- DSE, model 6020 Automatic Mains Failure module
- Static battery charger
- Emergency stop push button

### DSE 6020 Module Features

- Automatic controls generating set, start and stop
- 3 phase generator and mains voltage monitoring
- Transfer between mains and generator power
- LCD display shows the status of the generator at all time
- 4- line, 64 x 132 graphic display with LED backlight
- PC and front panel configurable
- Easy push button control

STOP/RESET – MANUAL – AUTOMATIC - TEST - START

Display Scroll button

Page button

### Metering via LCD display

- Generator Volt (L-L, L-N)
- Generator Ampere (L1, L2, L3)
- Generator Frequency (Hz)
- Mains Volt (L-L / L- N)
- Mains Frequency
- Engine cooling temperature
- Engine oil pressure
- Engine speed
- Engine hours run
- Engine battery volt
- Engine maintenance due
- Event Log (5) events

### Protections

#### Warnings

- Generator High/Low Voltage
- Generator Over/ Under Frequency
- Over /Under Speed
- Engine low oil pressure
- High coolant temperature
- Battery High / Low voltage
- Charge alternator failure
- Fail to stop

#### Shutdowns

- Generator High/ Low Voltage
- Generator Over/ Under Frequency
- Over /Under Speed
- Engine low oil pressure
- High coolant temperature
- Fail to stop
- Emergency stop
- Over current
- Fail to start
- Oil pressure sensor open circuit
- Temperature sensor open circuit

### LED display

- Mains Available
- Mains On Load
- Generator Available
- Generator On Load

## 17. THE PLACEMENT AND INTALLATION OF TRANSFER SWITCH

The placement of the transfer switch and its mountings:

- Position the transfer switch near the emergency power panel.
- Locate the transfer switch in a place where it is clean, not over- heated, and having a good ventilation. If the environment temperature is above 40°C, breakers will open more easily. There must be enough working place around the transfer switch.
- Having breaker between the generating set and the transfer switch is optional. Current from the generating set must be distributed equally to the three phase if possible.
- Current from one phase should not exceed the nominal current.
- If the transfer switch panel is apart from the generating set, transfer switch must be placed as close possible to the distributor panel.
- In this case power cables are drawn from generating set, mains panel and emergency power panel. Furthermore 8x2,5 mm<sup>2</sup> control cable must be drawn from the generating set control panel.

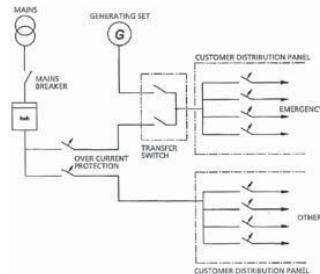

18.1 Typical emergency power system installation

## 18. ENGINE TROUBLESHOOTING

The starter motor turns the engine too slowly:

- Battery capacity too low
- Bad electrical connection
- Faulty in starter motor
- Wrong grade of lubricating oil

The engine does not start or difficult to start:

- Starter motor turns engine too slowly
- Fuel tank empty
- Faulty in fuel control solenoid
- Restriction in a fuel pipe
- Faulty in fuel lift pump
- Dirty fuel filter element
- Air in fuel system
- Faulty in atomisers
- Cold start systems used incorrectly
- Fault in cold start system
- Restriction in fuel tank vent
- Wrong type or grade of fuel used
- Restriction in exhaust pipe

**Not enough power:**

- Restriction in a fuel pipe
- Faulty in fuel lift pump
- Dirty fuel filter element
- Air in fuel system
- Restriction air filter/cleaner or induction system
- Restriction in exhaust pipe
- Fault in atomisers or atomisers of an incorrect type
- Restriction in fuel tank vent
- Wrong type or grade of fuel used
- Restricted movement of engine speed control
- Engine temperature is too high or low

**Misfire**

- Restriction in a fuel pipe
- Faulty in fuel lift pump
- Dirty fuel filter element
- Air in fuel system
- Fault in atomisers or atomisers of an incorrect type
- Fault in cold start system
- Engine temperature is too high
- Incorrect valve tip clearances

**The pressure of the lubrication oil is too low:**

- Wrong grade of lubrication
- Not enough lubrication oil in sump
- Defective gauge
- Dirty lubrication oil filter element

**High fuel consumption:**

- Restriction air filter/cleaner or induction system
- Fault in atomisers or atomisers of an incorrect type
- Fault in cold start system
- Wrong type or grade of fuel used
- Restricted movement of engine speed control
- Restriction in exhaust pipe
- Engine temperature is too low
- Incorrect valve tip clearances

**Black exhaust smoke:**

- Restriction air filter/cleaner or induction system
- Fault in atomisers or atomisers of an incorrect type
- Fault in cold start system
- Wrong type or grade of fuel used
- Restriction in exhaust pipe
- Engine temperature is too low
- Incorrect valve tip clearances
- Engine over load

**Blue or white exhaust smoke**

- Wrong grade of lubrication
- Fault in cold start system
- Engine temperature is too low

**The engine knocks:**

- Faulty in fuel lift pump
- Fault in atomisers or atomisers of an incorrect type
- Wrong type or grade of fuel used
- Fault in cold start system
- Engine temperature is too high
- Incorrect valve tip clearances

**The engine runs erratically:**

- Fault in fuel control
- Restriction in a fuel system
- Faulty in fuel lift pump

- Dirty fuel filter element
- Restriction air filter/cleaner or induction system
- Air in fuel system
- Fault in atomisers or atomisers of an incorrect type
- Fault in cold start system
- Restriction in fuel tank vent
- Restricted movement of engine speed control
- Engine temperature is too high
- In correct valve tip clearances

#### **Vibration**

- Fault in atomisers or atomisers of an incorrect type
- Restricted movement of engine speed control
- Engine temperature is too high
- Fan damaged
- Faulty in engine mounting or flywheel housing

#### **The engine temperature is too high:**

- Restriction air filter/cleaner or induction system
- Fault in atomisers or atomisers of an incorrect type
- Fault in cold start system
- Restriction in exhaust pipe
- Fan damaged
- Too much lubrication oil in sump
- Restriction in air or water passage of radiator
- Insufficient coolant system

#### **Crankcase pressure:**

- Restriction in breather pipe
- Vacuum pipe leaks or fault in exhauster

#### **Bad compression:**

- Restriction air filter/cleaner or induction system
- Incorrect valve tip clearances

#### **The engine starts and stops:**

- Dirty fuel filter element
- Restriction air filter/cleaner or induction system
- Air in fuel system

#### **The engine shuts down after approximately 15 seconds:**

- Bad connection towards oil pressure switch/coolant temperature switch

## **19. GENERATING SET MAINTENANCE**

A good maintenance program is the key to long generating set life. Maintenance and service should only be carried out by qualified technicians. The maintenance and service which are done must be recorded to the Maintenance Record Form. In general, the generating set should be kept clean. Do not permit liquids such as fuel or oil film to accumulate on any internal or external surfaces. Wipe down surfaces using an aqueous industrial cleaner:

### **19.1. Maintenance Schedule for Generator Sets**

#### **A. Daily or every 20 hours**

##### **Check**

- Visually inspect engine, generator, transfer switch and control panel.
- For, Oil, Water and Fuel leaks.
- For, Coolant level, Oil level, Fuel level
- Battery charge level
- Operation of coolant heater
- Drain Fuel/Water separator
- Inspect the engine fan blades
- Inspect the drive belt

#### **B. Weekly**

##### **Repeat Daily**

##### **Check**

##### **Fuel System**

- Fuel level in main tank
- Day tank float switch
- Fuel transfer pump operation
- Fuel lines and connections

##### **Cooling System**

- Adequate fresh air to engine
  - Hose and connections
  - Battery charging alternator belts
- Inspect the engine fan blades.  
Inspect the fan belt.

#### **Lubricating System**

- Oil level (Governor Housing)
- Tighten connections

#### **Exhaust System**

- Exhaust leaks
- Tighten connections
- Output voltage and frequency

#### **Transfer Switch**

- Operation under load
- No unusual sounds
- Terminals and connections normal colour
- Doors closed securely

### **C. 6 Months or 200 Hours**

#### **Repeat Weekly**

#### **Lubricating System**

- Change lubricating oil
- Change lubricating oil filters
- Clean crankcase breather

#### **Fuel System**

- Change fuel filters
- Drain sediment from main tank

#### **Governor**

- Change lubricating oil

#### **Cooling System**

- Check antifreeze
- Clean, exterior of radiator.
- Change water filter
- Lubricate with grease, bearing of the fan hub.

#### **Engine safety controls**

- Check operating alarms and safeties

### **C. 12 Months or 800 Hours**

#### **Repeat Maintenance "C"**

- Check the valves setting

#### **Fuel System**

- Analyze/replace diesel fuel

#### **Cooling System**

- Clean exterior of radiators

- Check coolant treatment
- Check anti-freeze solution
- Check water pumps and circulating pumps
- Replace, radiator's fill cap for ever 500 kVA.
- Examine duck work
- Clean/check motor operated louvers
- Clean, jacket water heater tube

#### **Intake System**

- Check air cleaner element and change at 635 mm H<sub>2</sub>O

#### **Clean**

- The engine
- Generator rotor and stator with compressed air

#### **Inspect**

- Magnetic pick-up and adjust
- Circuit breakers and fuse holders

#### **Generator**

- Measure/record generator winding resistance with Megger
- Perform full load test at Nameplate kW

### **D. 24 Months or 2,000 Hours**

#### **Check**

- Turbocharger bearing clearance
- Exhaust restriction
- The valves settings
- The injectors settings
- Vibration damper

#### **Change**

- Coolant and antifreeze and flush system
- Clean**
- Turbocharger compressor wheel and diffuser.

## GENERAL PRECAUTIONS ABOUT WARRANTY

### DEAR AKSA GENERATING SET OPERATOR,

PLEASE TAKE CARE TO THE FOLLOWING IN ORDER TO PREVENT THE GENERATING SET WARRANTY TO BECOME INVALID BEFORE THE TERMINATION OF THE WARRANTY PERIOD AND TO ENSURE TROUBLE-FREE OPERATION OF THE GENERATING SET WITH A LONG LIFE!

- o MAINTENANCE AND REPAIR WORKS WILL NOT BE COVERED BY THE WARRANTY UNLESS THE WARRANTY CERTIFICATE, INVOICE OR DELIVERY CERTIFICATE OF THE GENERATING SET IS SUBMITTED.
- o THE WARRANTY OF THE GENERATING SET WILL BECOME INVALID IN CASE OF ANY INTERVENTION OF ANY PERSON OTHER THAN AUTHORIZED AKSA SERVICES OR BY PRIOR WRITTEN APPROVAL FROM AKSA. POWER GENERATION ON THE GENERATING SET FOR ANY REASON.
- o CONTROL AND MAINTENANCE WORKS INDICATED IN THE PERIODICAL MAINTENANCE SCHEDULE AND THE OPERATING MANUAL MUST BE CARRIED OUT COMPLETELY AND TIMELY. THE FAILURES DUE TO INCOMPLETE OR UNTIMELY MAINTENANCE ARE NOT COVERED BY THE WARRANTY.
- o GENERATING SET SHOULD BE MOUNTED AS INDICATED IN THE OPERATING MANUAL. OTHERWISE, THE PROBLEMS WHICH ARE LIKELY TO OCCUR WILL NOT BE COVERED BY THE WARRANTY. CUSTOMER IS RESPONSIBLE FOR THE FAILURES WHICH ARE LIKELY TO OCCUR IN CASE THAT THE DIESEL OIL USED CONTAINS DIRT OR WATER.
- o THE OIL TYPE INDICATED IN THE OPERATING MANUAL SHOULD BE USED IN THE ENGINE. OTHERWISE, THE FAILURES WHICH ARE LIKELY TO OCCUR WILL NOT BE COVERED BY THE WARRANTY.
- o BATTERIES WILL NOT BE COVERED BY THE WARRANTY IF THEY ARE SUBJECT TO BREAKAGE, EXCESSIVE ACID FILL OR HARDENING BY LEAVING UNCHARGED.
- o ON MANUAL GENERATING SETS, NEVER START OR STOP THE DIESEL ENGINE WHEN THE GENERATING SET IS UNDER LOAD. ENGINE SHOULD BE STARTED AND STOPPED AFTER LOAD IS DISCONNECTED AND THE GENERATING SET IS AT IDLE CONDITION. OTHERWISE, THE VALVES CAN BE SEIZED, THE VOLTAGE REGULATOR, TRANSFORMER AND DIODES CAN BE BROKEN DOWN. THESE CONDITIONS ARE NOT COVERED BY THE WARRANTY.
- o OUR COMPANY DOES NOT TAKE THE RESPONSIBILITY OF THE DAMAGES ON THE MAINS SUPPLY CONTACTOR OF THE AUTOMATIC GENERATING SETS DUE TO OVERCURRENT, LOW OR HIGH VOLTAGE.
- o NEVER REMOVE THE BATTERY TERMINALS WHILE THE GENERATING SET IS IN USE. EVEN A MOMENT OF DISCONNECTION CAN CAUSE A DAMAGE ON THE ELECTRONIC CLOSING RELAY OF THE CHARGE ALTERNATOR AND ON THE ELECTRONIC ENGINE SPEED CONTROL CIRCUIT. THESE CONDITIONS ARE NOT COVERED BY THE WARRANTY.
- o FAILURES DUE TO OVERLOAD AND UNBALANCED LOAD IN EXCESS OF THE GENERATING SET POWER (SUCH AS ALTERNATOR AND CONTACTOR FAILURES) ARE NOT COVERED BY THE WARRANTY.
- o FAILURES DUE TO OVERLOAD AND UNBALANCED LOAD IN EXCESS OF THE GENERATING SET POWER (SUCH AS ALTERNATOR AND CONTACTOR FAILURES) ARE NOT COVERED BY THE WARRANTY.
- o WHEN THE MANUAL GENERATING SET IS STARTED UP, IT SHOULD BE WARMED BY OPERATING AT IDLE FOR 5 MINUTES. WHEN STOPPING THE DIESEL ENGINE, IT SHOULD BE UNLOADED AND THEN CONTINUED TO BE OPERATED FOR COOLING FOR 10 MINUTES BEFORE STOPPING. OTHERWISE, PROBLEMS WHICH ARE LIKELY TO OCCUR WILL NOT BE COVERED BY THE WARRANTY.
- o WARRANTY PERIOD IS 1 YEAR BEGINNING FROM THE PURCHASE DATE.





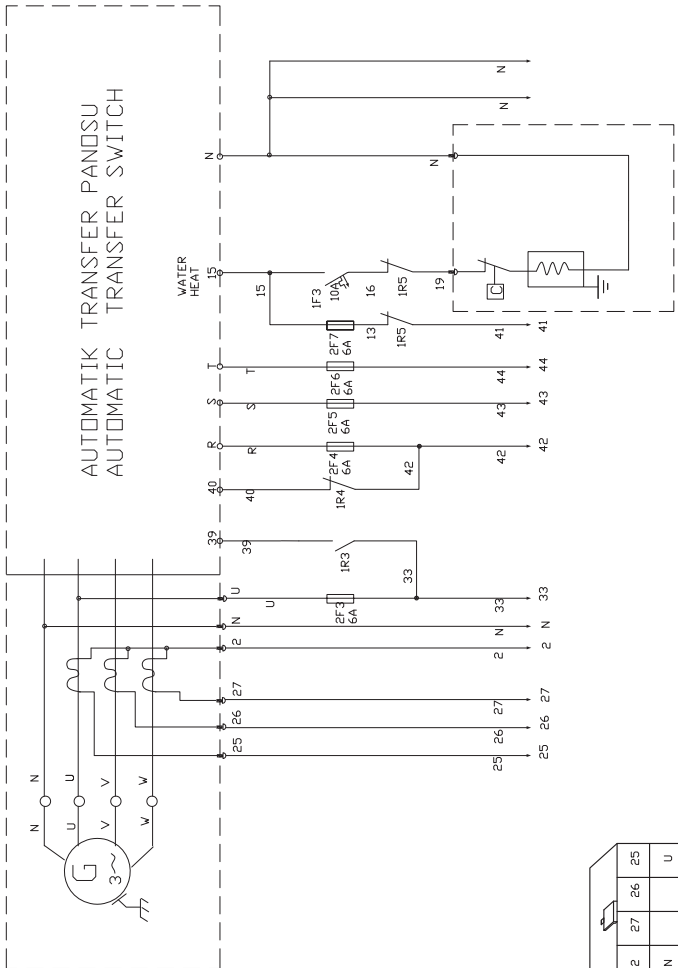

|   |    |    |    |   |
|---|----|----|----|---|
| 2 | 27 | 26 | 25 | U |
| N |    |    |    |   |

**COPYRIGHT RESERVED** ©  
 THE DESIGN AND DETAIL OF THIS DRAWING IS THE PROPERTY OF AKSA ENGINEERING. IT IS ISSUED ON THE STRICT UNDERSTANDING THAT IT IS TO BE USED ONLY FOR THE PROJECT SPECIFICALLY MENTIONED IN THE DRAWING. IT IS NOT TO BE REPRODUCED, COPIED OR COMMUNICATED TO ANY THIRD PARTY NOR BE USED FOR ANY OTHER PROJECT WITHOUT THE WRITTEN PERMISSION OF AKSA ENGINEERING. IN THE EVENT OF A DISPUTE, THE RESOLUTION OF ANY DISPUTE SHALL BE REFERRED TO THE ARBITRATOR. THE SUBJECT MATTER AS IT APPEARED AT THE RELEVANT DATE.

| CHISEL CODE | SCALE | 1:1  | MATERIAL | QUANTITY | WEIGHT |
|-------------|-------|------|----------|----------|--------|
|             | 3010  | DATE | REVISION | 1        |        |
|             | 3020  | DATE | REVISION |          |        |
|             | 3030  | DATE | REVISION |          |        |
|             | 3040  | DATE | REVISION |          |        |
|             | 3050  | DATE | REVISION |          |        |
|             | 3060  | DATE | REVISION |          |        |
|             | 3070  | DATE | REVISION |          |        |
|             | 3080  | DATE | REVISION |          |        |
|             | 3090  | DATE | REVISION |          |        |
|             | 3100  | DATE | REVISION |          |        |
|             | 3110  | DATE | REVISION |          |        |
|             | 3120  | DATE | REVISION |          |        |
|             | 3130  | DATE | REVISION |          |        |
|             | 3140  | DATE | REVISION |          |        |
|             | 3150  | DATE | REVISION |          |        |
|             | 3160  | DATE | REVISION |          |        |
|             | 3170  | DATE | REVISION |          |        |
|             | 3180  | DATE | REVISION |          |        |
|             | 3190  | DATE | REVISION |          |        |
|             | 3200  | DATE | REVISION |          |        |
|             | 3210  | DATE | REVISION |          |        |
|             | 3220  | DATE | REVISION |          |        |
|             | 3230  | DATE | REVISION |          |        |
|             | 3240  | DATE | REVISION |          |        |
|             | 3250  | DATE | REVISION |          |        |
|             | 3260  | DATE | REVISION |          |        |
|             | 3270  | DATE | REVISION |          |        |
|             | 3280  | DATE | REVISION |          |        |
|             | 3290  | DATE | REVISION |          |        |
|             | 3300  | DATE | REVISION |          |        |
|             | 3310  | DATE | REVISION |          |        |
|             | 3320  | DATE | REVISION |          |        |
|             | 3330  | DATE | REVISION |          |        |
|             | 3340  | DATE | REVISION |          |        |
|             | 3350  | DATE | REVISION |          |        |
|             | 3360  | DATE | REVISION |          |        |
|             | 3370  | DATE | REVISION |          |        |
|             | 3380  | DATE | REVISION |          |        |
|             | 3390  | DATE | REVISION |          |        |
|             | 3400  | DATE | REVISION |          |        |
|             | 3410  | DATE | REVISION |          |        |
|             | 3420  | DATE | REVISION |          |        |
|             | 3430  | DATE | REVISION |          |        |
|             | 3440  | DATE | REVISION |          |        |
|             | 3450  | DATE | REVISION |          |        |
|             | 3460  | DATE | REVISION |          |        |
|             | 3470  | DATE | REVISION |          |        |
|             | 3480  | DATE | REVISION |          |        |
|             | 3490  | DATE | REVISION |          |        |
|             | 3500  | DATE | REVISION |          |        |
|             | 3510  | DATE | REVISION |          |        |
|             | 3520  | DATE | REVISION |          |        |
|             | 3530  | DATE | REVISION |          |        |
|             | 3540  | DATE | REVISION |          |        |
|             | 3550  | DATE | REVISION |          |        |
|             | 3560  | DATE | REVISION |          |        |
|             | 3570  | DATE | REVISION |          |        |
|             | 3580  | DATE | REVISION |          |        |
|             | 3590  | DATE | REVISION |          |        |
|             | 3600  | DATE | REVISION |          |        |
|             | 3610  | DATE | REVISION |          |        |
|             | 3620  | DATE | REVISION |          |        |
|             | 3630  | DATE | REVISION |          |        |
|             | 3640  | DATE | REVISION |          |        |
|             | 3650  | DATE | REVISION |          |        |
|             | 3660  | DATE | REVISION |          |        |
|             | 3670  | DATE | REVISION |          |        |
|             | 3680  | DATE | REVISION |          |        |
|             | 3690  | DATE | REVISION |          |        |
|             | 3700  | DATE | REVISION |          |        |
|             | 3710  | DATE | REVISION |          |        |
|             | 3720  | DATE | REVISION |          |        |
|             | 3730  | DATE | REVISION |          |        |
|             | 3740  | DATE | REVISION |          |        |
|             | 3750  | DATE | REVISION |          |        |
|             | 3760  | DATE | REVISION |          |        |
|             | 3770  | DATE | REVISION |          |        |
|             | 3780  | DATE | REVISION |          |        |
|             | 3790  | DATE | REVISION |          |        |
|             | 3800  | DATE | REVISION |          |        |
|             | 3810  | DATE | REVISION |          |        |
|             | 3820  | DATE | REVISION |          |        |
|             | 3830  | DATE | REVISION |          |        |
|             | 3840  | DATE | REVISION |          |        |
|             | 3850  | DATE | REVISION |          |        |
|             | 3860  | DATE | REVISION |          |        |
|             | 3870  | DATE | REVISION |          |        |
|             | 3880  | DATE | REVISION |          |        |
|             | 3890  | DATE | REVISION |          |        |
|             | 3900  | DATE | REVISION |          |        |
|             | 3910  | DATE | REVISION |          |        |
|             | 3920  | DATE | REVISION |          |        |
|             | 3930  | DATE | REVISION |          |        |
|             | 3940  | DATE | REVISION |          |        |
|             | 3950  | DATE | REVISION |          |        |
|             | 3960  | DATE | REVISION |          |        |
|             | 3970  | DATE | REVISION |          |        |
|             | 3980  | DATE | REVISION |          |        |
|             | 3990  | DATE | REVISION |          |        |
|             | 4000  | DATE | REVISION |          |        |



AKSA ENGINEERING  
 DEPARTMENT: ENGINEERING  
 DRAWING NO.:  
 PART NO.:  
 LOCATION:  
 REVISION NO.: 00

© 2025 AKSA ENGINEERING. ALL RIGHTS RESERVED.









OTOMATIK TRANSFER PANOSU  
AUTOMATIC TRANSFER SWITCH

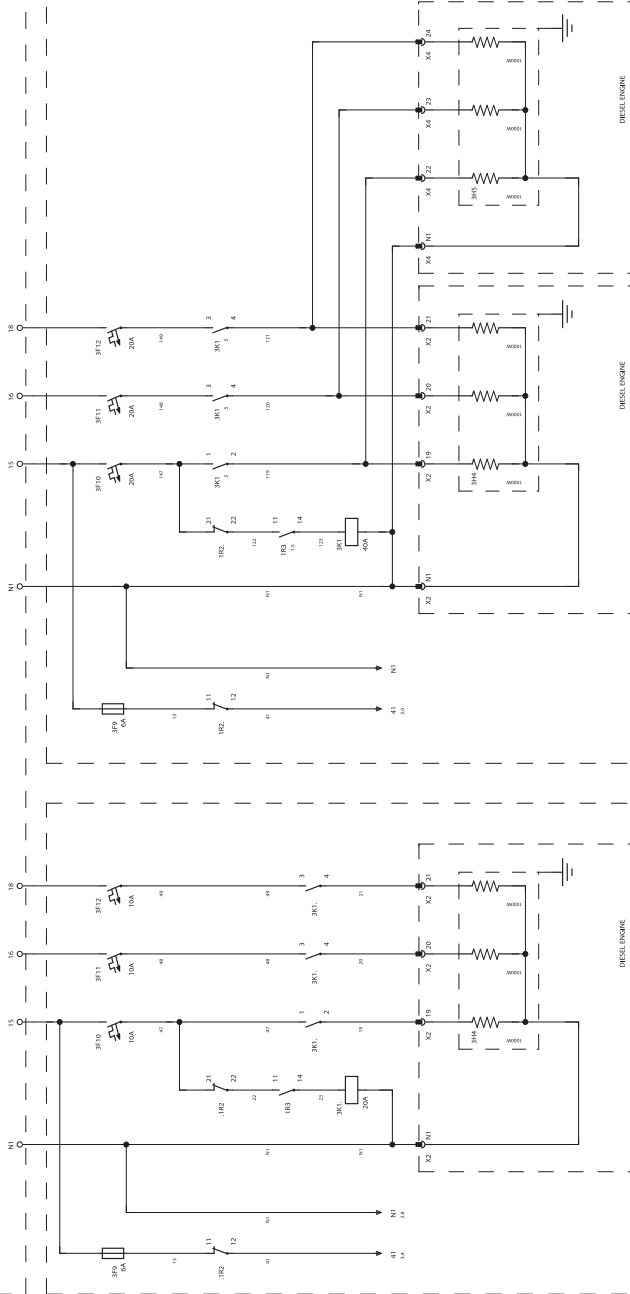

300-825KVA

1000-1675KVA



|  |                |  |        |
|--|----------------|--|--------|
| Scale:   | Drawing No:    | Revizyon:                                      | Scale: |
|  | 2550VA-1675KVA | BR/BRU   | BR/BRU |
| Date:  | 19.Feb.2010    | Approved:                                      | KOCANU |
| DSE-7320/AC SERISI<br>KONTROL PANOSU/CONTROL PANEL |                | BİTİCİ BAĞLANTISI<br>HEATER CONNECTION DIAGRAM |        |
| aksu<br>J E N E R A T Ö R                          |                | Sayfa No:<br>Sayfa Sayısı:<br>Toplam Sayfa:    |        |
|  |                | 3  |        |
|  |                | 4  |        |

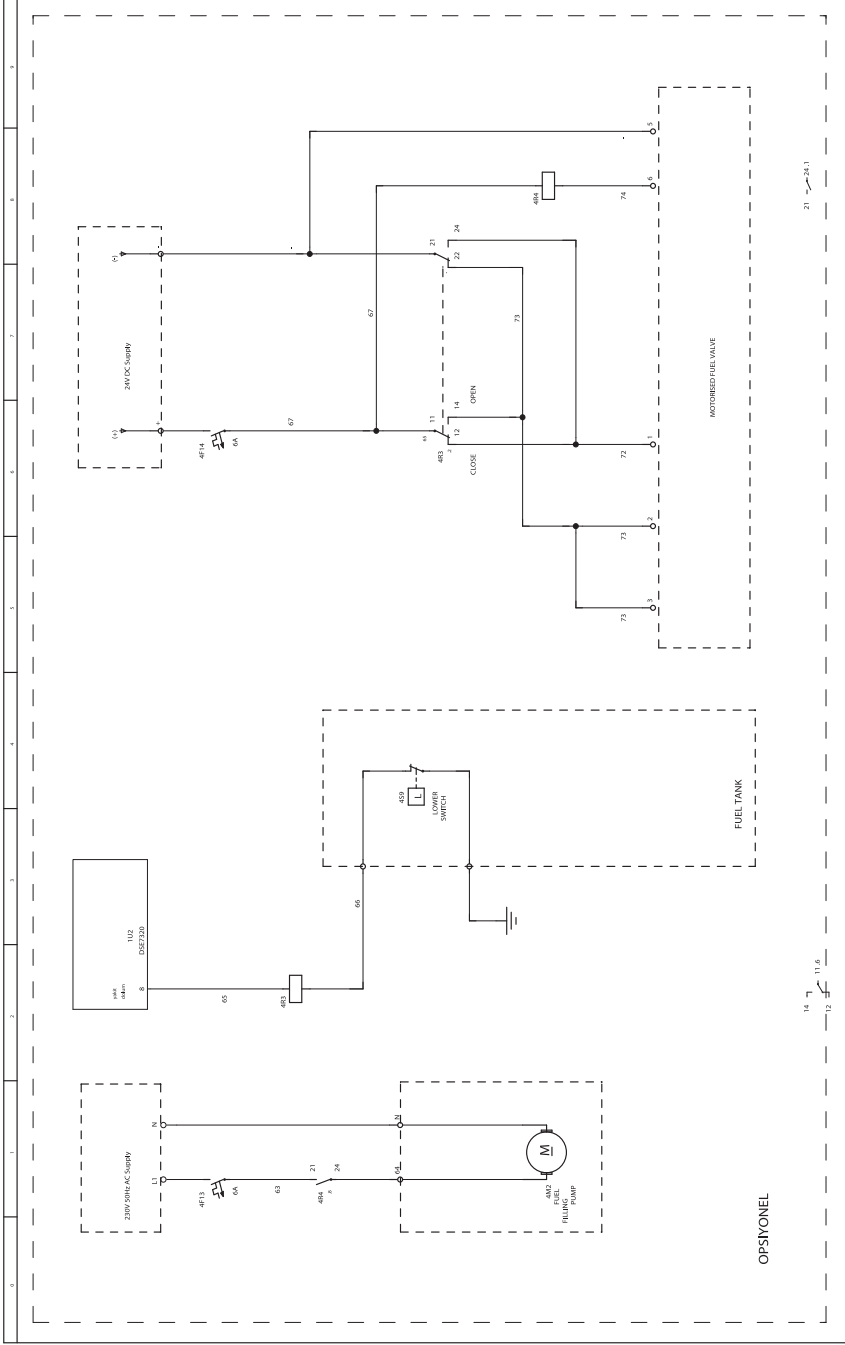

|             |         |           |                              |                                 |           |   |
|-------------|---------|-----------|------------------------------|---------------------------------|-----------|---|
| Scale:      | BBMMU   | Drawing:  | DSE-7320/AC SERISI           | OTOMATİK YAKIT DOLUM DEYRE SEMA | Revizyon: | 4 |
| Drawing No: | BBMMU   | Drawing:  | KONTROL PANOSU/KONTROL PANEL | AUTOMATIC FUEL FILLING          | Revizyon: | 4 |
| Date:       | KCCGANU | Approved: |                              |                                 | Revizyon: | 4 |
|             |         |           |                              |                                 | Revizyon: |   |







# AKSA JENERATÖR YETKİLİ SERVİS NOKTALARI

## İSTANBUL AVRUPA YAKASI

AVCILAR  
MUSTAFA KEMAL PAŞA MAH. YILDIRIM BEYAZIT CAD. DEMET SOK. NO:132 AVCILAR/İSTANBUL  
T:0 212 428 66 66 PBX F:0 212 423 22 22

BAĞCILAR  
ORTAK BÖLGE (GÖKSU) FATİH, ZEYTİNBURNU, GAZIOSMANPAŞA, EYÜP  
MERKEZ MAH. ATATÜRK CAD. NO:24 YENİBOSNA T:0212 630 79 80/0212 630 79 98

KAĞITHANE  
ÇAĞLAYAN MAH. KAĞITHANE CAD. NO:93 KAĞITHANE  
T:0212 222 13 38 PBX F:0212 210 08 81

KARAKÖY  
NECATİBEY CAD NO.74 KARAKÖY / İSTANBUL T: 0212 251 92 48 - 293 07 32 - 33 F: 0212 251 92 64  
DOLAPDERE SAN. SİT. 13.ADA NO:9 İKİTELLİ T: 0212 671 35 48 - 49 F: 0212 671 35 41

SEFAKÖY  
YEŞİLOVA MAH. DİLEK SOK. NO:2 KÜÇÜKÇEKMECE  
T:0212 425 65 80 (3 HAT) F:0212 425 65 84

## İSTANBUL ANADOLU YAKASI

KADIKÖY  
ESKİ ÜSKÜDAR YOLU CAD. MEZARLIK SK. NO:4 İÇERENKÖY  
T:0216 469 58 58

PENDİK  
AYDINEVLER AŞIK VEYSEL SOK. AK PLAZA NO:24 KÜÇÜKYALI/MALTEPE  
T:0216 489 68 68 PBX F:0216 489 21 60

## İSTANBUL DIŞI SERVİS NOKTALARI

ANKARA  
ÇETİN EMEÇ BULVARI 2.CAD. 1309 SK. NO:7/A ÖVEÇLER  
T:0312 472 71 71 F:0312 472 76 01

ADANA  
TURHAN CEMAL BERİKER BUL. MERKEZ CAD.  
ADANA İŞ MERKEZİ A BLOK NO:24/27 YEŞİLOBA SEYHAN  
T:0322 428 11 61 PBX F: 0322 428 15 40

ANTALYA  
YEŞİLOVA MAH. ASPENOS BULVARI 196-I  
T:0242 322 16 88 – 322 91 88 F:0242 322 97 55

BODRUM  
ATATÜRK BUL. BEYLİKKIRLARI MEVKİİ  
BALKANOĞLU-2 İŞ MERKEZİ G-BLOK NO:1 KONACIK  
T:0252 358 70 30 F: 0252 358 70 25

BURSA  
NİLÜFER TIC. MRK. ALAADDİNBEY MAH. 70 SK.  
NO:30/A NİLÜFER  
T:0224 443 53 15-16-17-18 F:0224 443 53 15

DENİZLİ  
İZMİR ASFALTI NO:56 GÜMÜŞLER  
T:0258 371 71 10/372 08 44 F:0258 372 09 46

GAZİANTEP  
FATİH MAH. FEVZİ ÇAKMAK BULVARI NO:152 ŞEHİTKÂMİL  
T:0342 321 39 59 F:0342 321 37 67

İZMİR  
KAZIM DİRİK MAH. YENİYOL ANKARA CAD.  
NO:75 BORNOVA  
T:0232 461 82 82 F:0232 462 24 63

KAYSERİ  
OSMAN KAVUNCU CAD. SOYLUM APT. NO:185/A  
MELİKGAZI T:0352 336 17 42-43 F: 0352 336 17 40

DİYARBAKIR  
URFA YOLU I. KM. DR. SİTKİ GÖRAL CAD.  
VELAT 3 APT.ALTI NO:1  
T:0412 238 04 44 PBX F:0412 238 10 11

MARMARIS  
DATÇA YOLU CAD. NO:14/B  
T:0252 413 58 93 F: 0252 413 85 93

TRABZON  
YAVUZ SELİM BULVARI MANOLYA SİTESİ NO:281  
T:0462 230 10 60-61 F: 0462 230 10 64

## BRANCH OFFICES & WAREHOUSES



### ALGERIA

Aksa Algeria  
Chemin du Parc d'Attraction  
Cooperative El Baraka No: 417 Tixerain  
Bir Mourad Rais / Alger  
T : + 213 21 40 26 72  
F : + 213 21 40 27 94  
e-mail: aksaalgeria@aksa.com.tr



### KAZAKHSTAN

Aksa Kazakhstan Ltd.  
M54-6 Abdullinyh Str.  
Corner of Tele Bi Str.  
Almaty - Kazakhstan  
T : + 7 727 250 67 31 / 250 67 41  
F : + 7 727 250 67 91  
e-mail: aksa@arna.kz



### U.A.E.

Aksa Middle East FZE  
Post Box:18167 Warehouse  
No.RA08 / LC07  
Jebel Ali Free Zone - Dubai  
T : + 971 4 880 91 40  
F : + 971 4 880 91 41  
e-mail: sales@aksa.ae



### CHINA

Aksa Power Generation  
(Changzhou) Co. Ltd.  
Export Processing Zone  
Xinzhu Road, Plant A1 - A2,  
Changzhou / China  
T : + 86 (0) 519 851 50 205  
F : + 86 (0) 519 851 50 130  
e-mail: aksa@aksapowergen.com



### RUSSIA

000 AKCA  
107031, Petravka, 27  
Moscow - Russia 7108862  
T : + 7 495 710 88 62  
F : + 7 495 641 52 00  
e-mail : info@aksarussia.ru



### UNITED KINGDOM

Aksa International (UK) Ltd  
Unit 6, Pine Court Walker Road,  
Bardon Hill Coalville Leicestershire,  
LE67 15Z U.Kingdom  
T : + 44 (0) 1530 837 472  
F : + 44 (0) 1530 519 577  
e-mail: sales@aksa-uk.com



### IRAQ

Aksa Power Generation (Iraq)  
English Village House  
No:353 Arbil / Iraq  
T : + 964 (0) 771 199 18 56  
e-mail: hakant@aksa.com.tr



### SINGAPORE

Aksa Far East(Pte.) Ltd.  
94 Tuas Avenue 11  
639103 Singapore  
T : + 65 6863 2832  
F : + 65 6863 0392 - 6863 2956  
e-mail: aksafe@aksafareast.com.sg



### VIETNAM

Aksa Vietnam  
43 Le Thi Hong Gam,  
Dist. 1, HCM City - Vietnam  
T : + 84 8 391 47 014  
F : + 84 8 391 47 015  
e-mail: apt@aksa.com.tr

**aksa**  
JENERATÖR

## AKSA JENERATÖR SANAYİİ A.Ş.



### DECLARATION OF CONFORMITY AT – UYGUNLUK BEYANI

Üretici / Manufacturer : AKSA Jeneratör San.A.Ş.  
Adres / Address : Gülbahar Cd. 1.Sokak, Güneşli 34212 İstanbul / Türkiye  
Ürün Kodu / Product Code : ...../.....  
Ürün Açıklaması : Otomatik Tip Kabinli Jeneratör  
Production Description : Automatic Generator With Canopy

#### Declarations / Declaration

AKSA Jeneratör San. A.Ş. olarak, yukarıda bilgileri verilmiş olan ürünün aşağıdaki Avrupa Birliği direktiflerine, standartlara ve bunların gerektirdiği şartlara uygun olduğunu beyan ederiz.

On behalf of AKSA Jeneratör San. A.Ş. We declare that above information in relation on the supply/manufacture of this in product is in conformity with the below stated standards, EC directives and provisions of them.

#### Avrupa Birliği Direktifleri / EC Directives

2006/42/AT : Makine Emniyeti Yönetmeliği  
2006/42/EC : Machinery Safety Directive  
2004/108/AT : Elektromanyetik Uyumluluk Yönetmeliği  
2004/108/EC : Electromagnetic Compatibility Directive  
2006/95/AT : Alçak Gerilim Yönetmeliği  
2006/95/EC : Low Voltage Directive

#### Standartlar / Standards

- TS EN ISO 12100-1:2007 : Makinelerde Güvenlik - Temel Kavramlar, Tasarım İçin Genel Prensipler -Bölüm 1: Temel Terminoloji, Met.  
EN ISO 12100-1:2003 : Safety of Machinery - Basic Concepts, General Principles For Design-Part 1: Basic Terminology, Methodology
- TS EN ISO 12100-2:2007 : Makinelerde Güvenlik - Temel Kavramlar, Tasarım İçin Genel Prensipler -Bölüm 2: Teknik Prensipler  
EN ISO 12100-2:2003 : Safety of Machinery - Basic Concepts, General Principles For Design-Part 2: Technical Principles
- TS EN 614-1 : Makinelerde Güvenlik-Ergonomik Tasarım Prensipleri-Bölüm 1:Terminoloji ve Genel Prensipler  
EN 614-1:2006 : Safety of Machinery-Ergonomic Design Principles-Part 1-Terminology And General Principles
- TS EN 60204-1 : Makinelerde Güvenlik - Makinelerin Elektrik Teçhizatı - Bölüm 1: Genel Kurallar  
EN 60204-1:2006 : Safety of Machinery-Electrical Equipment Of Machines General Requirements
- TS EN 12601 : Gidip Gelmeli İçten Yanmalı Motor Tahrikli Jeneratör Grupları- Güvenlik  
EN 12601:2001 : Reciprocating Internal Combustion Engine-Driven Generating Sets-Safety
- TS EN ISO 14121-1 : Makinelerde Güvenlik- Risk değerlendirmesi - Bölüm 1: Prensipler  
EN ISO 14121-1 : Safety of Machinery-Risk Assessment-Part 1: Principles
- TS EN 61000-4-2:2009 :Elektromanyetik Uyumluluk (EMU)-Bölüm 4-2: Deney ve Ölçme Teknikleri -Elektrostatik Boşalma Bağışıklık Deneyi  
BS EN 61000-4-2:2009 :Electromagnetic Cmpatibility (EMC). Testing And Measurement Techniques. Electrostatic Discharge Immunity Test
- TS EN 61000-4-6:2009 : Elektromanyetik Uyumluluk (EMC)- Bölüm 4-6: Deney ve Ölçme Teknikleri- Radyo Frekans Alanlarının Neden Olduğu Temaslı Rahatsızlıklara Karşı Bağışıklık  
BS EN 61000-4-6:2009 : Electromagnetic Compatibility (EMC). Testing And Measurement Techniques. Immunity to Conducted Disturbance Induced By Radio-Frequency Fields

Yayın / Issued by : AKSA Jeneratör San. A.Ş.  
Yer-Tarih / Place-Date : İstanbul - .....  
Firma Adına Yetkili : Mustafa KÜÇÜKBAŞ  
Name of Authorized Representative  
Unvan / Title : İşletme Müdürü  
İmza / Signature :



## AKSA JENERATÖR SANAYİİ A.Ş.



### DECLARATION OF CONFORMITY AT – UYGUNLUK BEYANI

Üretici / Manufacturer : AKSA Jeneratör San.A.Ş.  
Adres / Adress : Gülbahar Cd. 1.Sokak, Güneşli 34212 İstanbul / Türkiye  
Ürün Kodu / Product Code : ...../.....  
Ürün Açıklaması : Otomatik Tip Açık Jeneratör  
Production Description : Automatic Generator With Out Canopy

#### Declarations / Declaration

AKSA Jeneratör San. A.Ş. olarak, yukarıda bilgileri verilmiş olan ürünün aşağıdaki Avrupa Birliği direktiflerine, standartlara ve bunların gerektirdiği şartlara uygun olduğunu beyan ederiz.

On behalf of AKSA Jeneratör San. A.Ş. We declare that above information in relation on the supply/manufacture of this in product is in conformity with the below stated standards, EC directives and provisions of them.

#### Avrupa Birliği Direktifleri / EC Directives

2006/42/AT : Makine Emniyeti Yönetmeliği  
2006/42/EC : Machinery Safety Directive  
2004/108/AT : Elektromanyetik Uyumluluk Yönetmeliği  
2004/108/EC : Electromagnetic Compatibility Directive  
2006/95/AT : Alçak Gerilim Yönetmeliği  
2006/95/EC : Low Voltage Directive

#### Standartlar / Standards

- TS EN ISO 12100-1:2007 : Makinelerde Güvenlik - Temel Kavramlar, Tasarım İçin Genel Prensipler -Bölüm 1: Temel Terminoloji, Metodoloji  
EN ISO 12100-1:2003 : Safety of Machinery - Basic Concepts, General Principles For Design-Part 1: Basic Terminology, Methodology
- TS EN ISO 12100-2:2007 : Makinelerde Güvenlik - Temel Kavramlar, Tasarım İçin Genel Prensipler -Bölüm 2: Teknik Prensipler  
EN ISO 12100-2:2003 : Safety of Machinery - Basic Concepts, General Principles For Design-Part 2: Technical Principles
- TS EN 614-1 : Makinelerde Güvenlik-Ergonomik Tasarım Prensipleri-Bölüm 1:Terminoloji ve Genel Prensipler  
EN 614-1:2006 : Safety of Machinery-Ergonomic Design Principles-Part 1-Terminology And General Principles
- TS EN 60204-1 : Makinelerde Güvenlik - Makinelerin Elektrik Teçhizatı - Bölüm 1: Genel Kurallar  
EN 60204-1:2006 : Safety of Machinery-Electrical Equipment Of Machines General Requirements
- TS EN 12601 : Gidip Gelmeli İçten Yanmalı Motor Tahrikli Jeneratör Grupları- Güvenlik  
EN 12601:2001 : Reciprocating Internal Combustion Engine-Driven Generating Sets-Safety
- TS EN ISO 14121-1 : Makinelerde Güvenlik- Risk değerlendirmesi - Bölüm 1: Prensipler  
EN ISO 14121-1 : Safety of Machinery-Risk Assessment-Part 1: Principles
- TS EN 61000-4-2:2009 :Elektromanyetik Uyumluluk (EMU)-Bölüm 4-2: Deney ve Ölçme Teknikleri -Elektrostatik Boşalma Bağışıklık Deneyi  
BS EN 61000-4-2:2009 :Electromagnetic Cmpatibility (EMC). Testing And Measurement Techniques. Electrostatic Discharge Immunity Test
- TS EN 61000-4-6:2009 : Elektromanyetik Uyumluluk (EMC)- Bölüm 4-6: Deney ve Ölçme Teknikleri- Radyo Frekans Alanlarının Neden Olduğu Temaslı Rahatsızlıklara Karşı Bağışıklık  
BS EN 61000-4-6:2009 : Electromagnetic Compatibility (EMC). Testing And Measurement Techniques. Immunity to Conducted Disturbance Induced By Radio-Frequency Fields

Yayın / Issued by : AKSA Jeneratör San. A.Ş.  
Yer-Tarih / Place-Date : İstanbul - .....  
Firma Adına Yetkili : Mustafa KÜÇÜKBAŞ  
Name of Authorized Representative  
Unvan / Title : İşletme Müdürü  
İmza / Signature :

**aksa**  
JENERATÖR

## SANAYİ VE TİCARET BAKANLIĞI GARANTİ BELGESİ

Bu belgenin kullanılmasında; 4077 sayılı Tüketicinin Korunması Hakkında Kanun ve bu Kanuna dayanılarak yürürlüğe konulan Garanti Belgesi Uygulama Esasları na Dair Yönetmelik uyarınca, TC. Sanayi ve Ticaret Bakanlığı Tüketicinin ve Rekabetin Korunması Genel Müdürlüğü tarafından izin verilmiştir.

Belge Numarası : 85233

Belge İzin Tarihi : 18-06-2010

| MALIN;                 |                                   |
|------------------------|-----------------------------------|
| CİNSİ                  | MALIN TÜKETİCİYE<br>TESLİM TARİHİ |
| MARKASI                | MALIN TÜKETİCİYE<br>TESLİM YERİ   |
| MODELİ / SERİ NUMARASI | FATURA TARİHİ/<br>FATURA SAYISI   |

| İMALATÇI VEYA İTHALATÇI FİRMANIN |  |
|----------------------------------|--|
| ÜNVANI                           | AKSA JENERATÖR SANAYİ ANONİM ŞİRKETİ   |
| MERKEZ ADRESİ                    | GÜLBAHAR CADDESİ, 1.SOKAK, 34212<br>GÜNEŞLİ/İSTANBUL                               |
| TEL / FAX                        | 0.212 478 66 66 / 0.212 657 55 16  |
| YETKİLİ KİŞİ / ÜNVANI            | GENEL MÜDÜR  |
| YETKİLİ KİŞİ İMZA / KAŞE         |  |

| SATIÇI FİRMANIN;         |  |
|--------------------------|--|
| ÜNVANI                   |  |
| ADRESİ                   |  |
| TEL/FAX                  |  |
| YETKİLİ KİŞİ / ÜNVANI    |  |
| YETKİLİ KİŞİ İMZA / KAŞE |  |



